

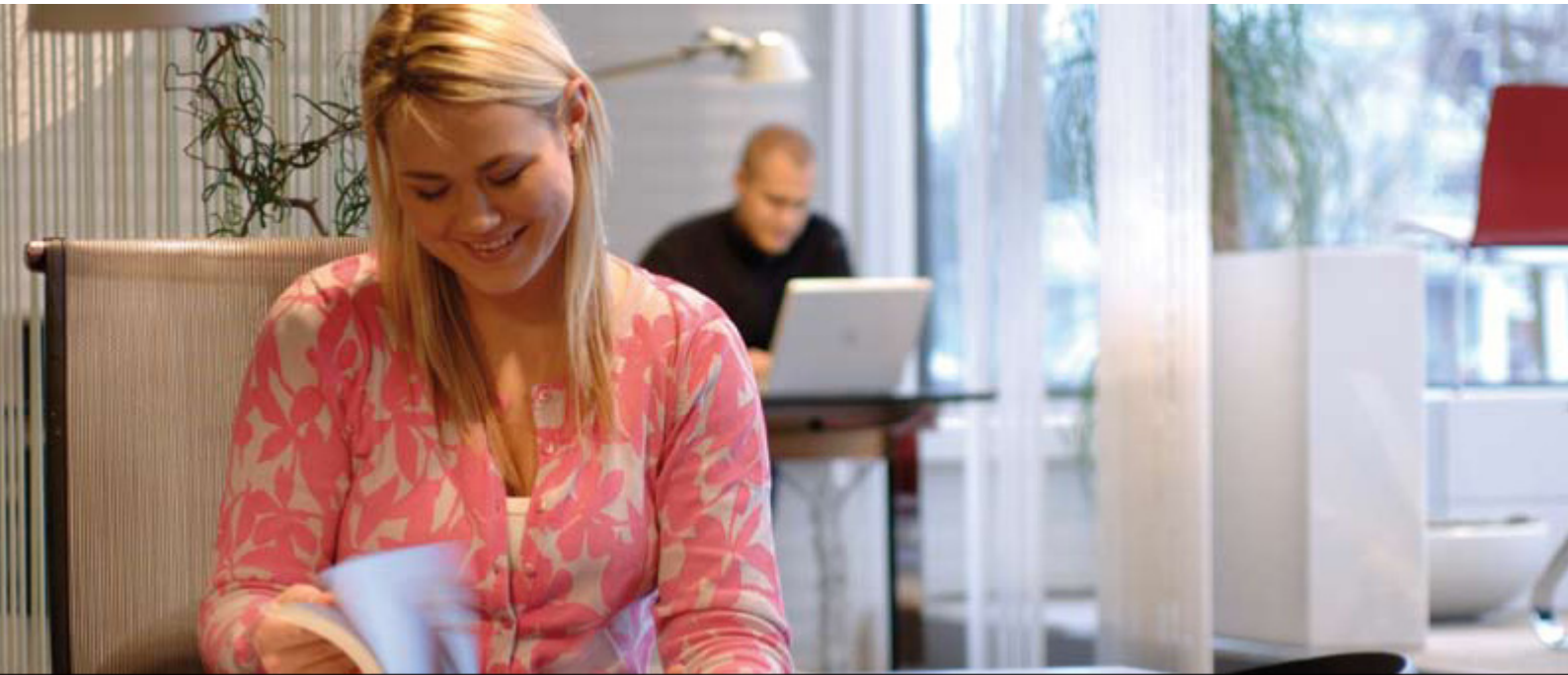

Regio Maxi - Manual



REGIN

THE CHALLENGER IN BUILDING AUTOMATION

DISCLAIMER

The information in this manual has been carefully checked and is believed to be correct. Regin however, makes no warranties as regards the contents of this manual and users are requested to report errors, discrepancies or ambiguities to Regin, so that corrections may be made in future editions. The information in this document is subject to change without prior notification.

The software described in this document is supplied under license by Regin and may be used or copied only in accordance with the terms of the license. No part of this document may be reproduced or transmitted in any form, in any fashion, electronically or mechanically, without the express, written permission of Regin.

COPYRIGHT

© AB Regin. All rights reserved.

TRADEMARKS

EXOdesigner, EXOreal, EXO4, EXOline, EXO4 Web Server, Regio and Regio tool[®] are registered trademarks of AB Regin.

Windows, Windows 2000, Windows XP, and Windows Server 2003 are registered trademarks of Microsoft Corporation.

Some product names mentioned in this document are used for identification purposes only and may be the registered trademarks of their respective companies.

August 2011

Contents At a Glance

<i>Part I Introduction</i>	4
<i>Chapter 1</i> About the manual	6
<i>Chapter 2</i> Introduction to Regio Maxi	7
<i>Chapter 3</i> Models	10
<i>Chapter 4</i> Technical data	13
<i>Part II Installation</i>	16
<i>Chapter 5</i> Installation preparations	18
<i>Chapter 6</i> Installation	20
<i>Chapter 7</i> Commissioning	46
<i>Part III Configuration</i>	47
<i>Chapter 8</i> Control states	49
<i>Chapter 9</i> Operating modes	52
<i>Chapter 10</i> Setpoint calculation	57
<i>Chapter 11</i> Actuators	59
<i>Chapter 12</i> Fan control	60
<i>Chapter 13</i> Change-over function	61
<i>Chapter 14</i> Forced ventilation / Condensation detector / Frost protection	62
<i>Chapter 15</i> Indications	63
<i>Chapter 16</i> Functions for RU-DOS	65
<i>Chapter 17</i> Display handling	67
<i>Part IV Maintenance and service</i>	74
<i>Chapter 18</i> Maintenance and service	76
<i>Part V Signals</i>	78
<i>Chapter 19</i> Signal types	80
<i>Chapter 20</i> Signals	82
<i>Part VI Index</i>	96

Part I Introduction

Table of contents

Part I Introduction

Chapter 1 About the manual	6
Terms	6
More information	6
Chapter 2 Introduction to Regio Maxi	7
Regio zone controllers	7
Regio Maxi	8
Chapter 3 Models	10
RCP-units	10
Design of the RCP-models	10
RU-units	11
Design of the RU-models	12
Chapter 4 Technical data	13
Common data	13
RCP	13
RU	15
Accessories for Regio Maxi	15

Chapter 1 About the manual

This manual covers all the models in the Regio Maxi range. This revision covers program revisions from 1.3-1-01.

Terms

Term used in the manual:

FS Factory setting

More information

More information about Regio Maxi can be found in:

- **Regio tool[®] Manual** – Describes how you configure the controllers using Regio tool[®]
- **Regio in EXO 2005 Projects** – Information on how to use Regio in the EXO system
- **Regio Room Controllers** – Brochure for the Regio series

The information is available for download from Regin's homepage, www.regin.se.

Chapter 2 Introduction to Regio Maxi

Regio zone controllers

Regio is a wide series of room controllers which handle everything from heating, cooling and ventilation to lighting, humidity, CO₂ monitoring and blinds. Regio can be used for creating everything from stand-alone systems for managing the functions in one room, to large, integrated systems with a comprehensive SCADA-system.

Regio also offers web and Internet solutions. Temperature and other functions in a room can be individually controlled from a PC connected to the office network.

Mini, Midi, Maxi

The Regio controllers are divided into three different series, Mini, Midi and Maxi.

Mini (RC) are 24 V AC stand-alone controllers for controlling heating and cooling in a room. The series consists of different room control units and a relay box for fan control. The control units are pre-programmed to handle different functions and can easily be configured. They have a built-in temperature sensor, but an external temperature sensor can also be connected.

The Midi controllers (RC-C) have the same characteristics as Mini. They can be used stand-alone or in a system with communication. The controllers are connected to bus lines such as Modbus or Regin's own bus system EXOline, to communicate with a central SCADA-system via RS485. They can also be configured for a specific application with Regin's software tool Regio tool[®].

Maxi (RCP) are 230 V AC freely programmable room controllers for handling all functions in a zone system. The controllers are pre-programmed but can be configured using Regio tool[®]. Different room units (RU-units) with built-in temperature sensor are connected to the controllers. Maxi can be connected to standardised bus systems like Modbus or EXOline, with communication via TCP/IP, RS485 or LON, and integrated with a central SCADA-system. Using EXO4 Web Server, all functions can be handled from a PC with Internet Explorer and no room units are needed. This will keep the investment down.

Awarded design

Regio has a modern design which enhances the indoor environment. The design has been awarded the 2007 "iF product design award", which more than 1100 participants from over 30 countries compete for every year. The contributions are judged by an international panel, according to a large number of criteria. The competition has been running for 53 years and is one of the most acknowledged design competitions in the world.

Applications

The Regio controllers have appealing design and functionality. They are suitable in buildings where you want optimal comfort and low energy consumption, for example offices, schools, shopping centres, airports, hotels and hospitals.

Mounting

The modular design with a separate bottom plate for wiring makes the whole Regio series easy to install and commission.

Regio Maxi

Communication The Maxi controllers (RCP-controllers) can be connected to a central SCADA-system via RS485 (EXoline or Modbus), TCP/IP or LON and configured for a particular application using the configuration tool Regio tool[®], which can be downloaded free of charge from Regin's homepage www.regin.se. See the manual for Regio tool[®] for more information.

LON communication Models with LON communication use LonWorks, adjusted according to the LonMark guidelines. See the LonWorks network variable list in chapter 20.

LON communicates via the LON port on the RCP-unit. The configuration takes place on the display of the RU-unit or via Regio tool[®] on a PC connected via the RS485 port on the RCP-unit. The RCP-unit should be installed in the LON network with the help of LonMaker or a corresponding computer program.

Control states The controllers can be configured for different control states/control sequences:

- Heating
- Heating or cooling via the change-over function
- Heating/Heating
- Heating/Cooling
- Heating/Cooling with VAV-control and forced supply air function
- Heating/Cooling with VAV-control
- Cooling
- Cooling/Cooling

All RCP-models can be used for controlling thermal actuators and three-point actuators. The RCP200...-models can also control 0...10 V actuators, and the RCP...F...-models can be used for fan coil control.

Application examples

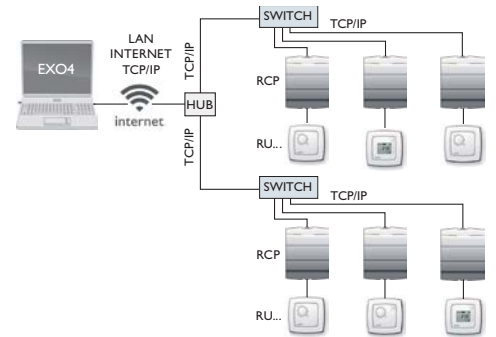
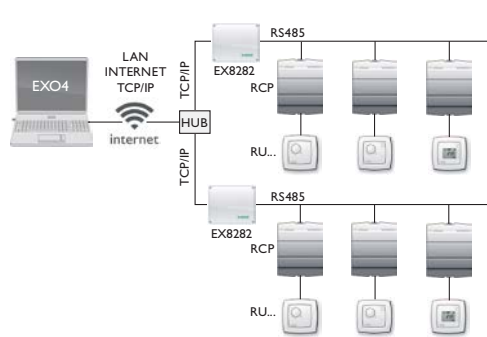
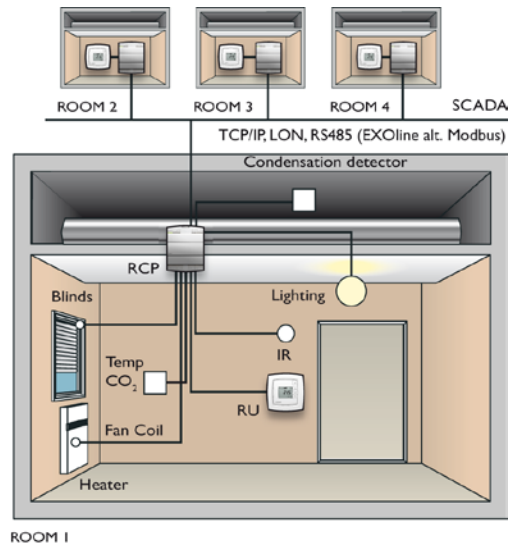

Chapter 3 Models

Regio Maxi consists of RCP- and RU-units, which are connected with a RJ12-cable.

RCP-units

There are 12 different RCP-controllers in the Maxi series. They can be divided according to type of control, see table 1 below.

Models	Functions	RS485 port	TCP/IP port	LON port	Fan control	Can be combined with RU-model
Models for control of thermal actuators and/or three-point actuators	RCP100	•				RU, RU-O, RU-DO, RU-DOS
	RCP100T		•			
	RCP100L			•		
Models for control of thermal actuators and/or three-point actuators, and fan coil	RCP100F	•			•	RU-F, RU-FO, RU-DFO, RU-DOS
	RCP100FT		•		•	
	RCP100FL			•	•	
Models for control of 0...10 V-actuators and/or thermal actuators and/or three-point actuators	RCP200	•				RU, RU-O, RU-DO, RU-DOS
	RCP200T		•			
	RCP200L			•		
Models for control of 0...10 V-actuators and/or thermal actuators and/or three-point actuators, and fan coil	RCP200F	•			•	RU-F, RU-FO, RU-DFO, RU-DOS
	RCP200FT		•		•	
	RCP200FL			•	•	

Table 1. The RCP-models and their functions

Design of the RCP-models



RU-units

There are 7 different room units in the Maxi series. They can be divided according to type of control into basic models, models for fan control and a flexible model with special functions (RU-DOS). For information on how the RU-units can be combined with the RCP-controllers, see table 1 on page 9.

Basic models

Basic models can be used in installations with 0...10 V actuators, thermal actuators or three-point actuators.

RU-F-models

RU-models for fan control (RU-F-models) can be used for the same applications as the basic models. They also have a fan button/switch for controlling a three-speed fan (fan coil, etc.).

RU-DOS

RU-DOS can be used for the same applications as the basic models and the RU-F-models. It also has special functions like lighting control, CO₂-control, control of blinds, display of humidity and outdoor temperature. Read more in the chapter *Functions with RU-DOS*.

Model	Functions	Display	Occupancy button	CO ₂ , blinds, humidity lighting, outdoor temp	Fan control	Setpoint knob
Basic models without fan control	RU					•
	RU-O		•			•
	RU-DO	•	•			
Models for fan control (RU-F-models)	RU-F				•	•
	RU-FO		•		•	•
	RU-DFO	•	•		•	
Model with special functions	RU-DOS	•	•	•	•	

Table 2. The RU-models and their functions

Design of the RU-models

RU



RU-O



RU-DO



RU-F



RU-FO



RU-DFO



RU-DOS



Chapter 4 Technical data

The data concerns all models. For available I/O for a certain model, see the chapter *Installation*.

Common data

Ambient operation temperature	0...50°C
Ambient transport and storage temperature	-20...70°C
Ambient humidity	Max 95% RH
Material casing	Polycarbonate, PC

LVD, Low Voltage Directive

This product conforms with the requirements of European LVD standard IEC 60 730-1.

EMC emission and immunity standard

This product conforms with the requirements of European EMC standards CENELEC EN 61000-6-1 and EN 61000-6-3 and carries the CE mark.

RCP

Supply voltage	230 V AC +/- 10%, 50/60 Hz
Fuse	Internal, automatic
Power consumption, internal electronics	2 VA
Operation	
Climatic conditions according to IEC 721-3-3	Class 3k5
Mechanical requirements according to IEC721-3-3	Class 3M3
Vibration	IEC60068-2-6, Test FC, vibration Sinusoidal
Shock	IEC60068-2-27, Test Ea
Transport	
Climatic conditions according to IEC 721-3-2	Class 2k3
Mechanical requirements according to IEC721-3-2	Class 2M2
Vibration	IEC60068-2-6, Test FC, vibration Sinusoidal
Shock	IEC60068-2-27, Test Ea
Free fall	IEC60068-2-27, Test Ed
Storage	
Climatic conditions according to IEC 721-3-1	Class 1k3
Built-in transformer, max capacity	30 VA
Max power consumption for fuse	30 VA
Inputs	See connection tables in the chapter <i>Wiring</i>
Terminal blocks	So-called lift type for cable cross-section 2.1 mm ²
Protection class	IP20
Weight	780 g
Casing	EURO-norm
Mounting	
alternative	In the ceiling void
alternative	In a cabinet front with a separate mounting kit
alternative	On a TS35 DIN-rail
Operating system	EXOreal
Real-time clock (RTC)	No
Dimensions	150 x 180 x 60 mm

Battery backup

Type.....Lithium, CR2032
Battery backup of RAM at least 5 years
Battery monitoring of RAM Yes

Communication port, Port 1

TypeRS485 (EXoline or Modbus) with automatic detection/change-over
Modbus8 bits, 1 or 2 stop bits. Odd, even (FS) or no parity
Communication speed Modbus 300, 600, 1200, 2400, 4800, 9600 or 19200 bps
Communication speed EXoline 9600 bps
Galvanic isolation from the rest of the electronics, common mode voltageMax 150 V
Data for models with TCP/IP port
Connection 10Base-T/100Base-TX auto-negotiation (RJ45)
Cable length Max 100 m (min Cat 5)
Protocol EXoline-TCP
Port 1 available on TCP/IP-modelsNo
LonWorks FT3150, gives a second communication port

Analogue inputs, AI

Temperature (PT1000)-50 +/- 150°C
accuracy (excluding sensor) +/- 0.4°C
Voltage0...10 V
input resistance 10 MOhm
accuracy (% of full scale) +/- 0.15%

Analogue outputs, AO

Output level 0...10 V DC
Max load..... 5 mA, short circuit proof

Digital inputs, DI

Type..... 24 V DC, floating contact, powered from 24 V DC output, pin 80 and 83
Logic 0..... 0...5 V DC
input current at 0 V0 mA
input resistance8 kOhm
Logic 1 12...24 V DC
input current at 24 V DC 3 mA

Condensation input, CI

Type.....Regin's condensation detector, KG-A/1

24 V DC-output, +C

Output level on +C24 V DC +/- 2 V
Max total load..... 0.1 A, short circuit proof

GDO, 24 V AC-output for power supply of actuators etc.

Output level on GDO..... 24...30 V AC depending on the load
Max total load on terminals 20, 23 and 26 (connected internally) 12 VA

Digital outputs, DO4-7 (MosFet)

Type..... 24 V AC
Max continuous load is limited by available power on GDO
.....See GDO for available power for all DO:s
Max transient load for each DO..... 4.0 A, 50 ms

Digital outputs, DO1-3 (Relay)

Type.....Closing, NO
Contact data
Max switching voltage..... 250 V AC

Min switching voltage.....	12 V AC
Max continuous current DO1-3.....	4 A resistive load
Max continuous current Common, terminal 13.....	8 A resistive load
Max inrush current	20 A
Min switching current.....	10 mA
AC-connection	
Max switching power, resistive load.....	1000 VA
Insulation, coil-contact.....	4000 V _{RMS}

For more information about inputs and outputs, see the chapter *Wiring*.

RU

Supply voltage.....	Fed from RCP
Protection class.....	IP20
Weight	110 g
Max cable length between RU and RCP	30 m

Dimensions

Models without setpoint knob	95 x 95 x 28 mm
Models with setpoint knob	95 x 95 x 31 mm

Built-in temperature sensor

Type	NTC, linearised, 15 kOhm
Measuring range	0...50°C
Accuracy	+/-0.5°C at 15...30°C

RU with display

Display type	LCD with background illumination
--------------------	----------------------------------

Accessories for Regio Maxi

External temperature sensors.....	TG-R5/PT1000,TG-UH/PT1000,TG-A1/PT1000
Occupancy detector.....	IR24-P
Change-over	TG-A1/PT1000
Cable	Type RJ12, different lengths
CO ₂ -transmitter	CO2RT
Humidity sensor	HRT
Outdoor temperature sensor	TG-UH/PT1000
Cables for connection between RU and RCP	
Length 3 m	RU-CBL3
Length 10 m	RU-CBL10

The accessories are available from Regin. For more information, see the product sheets and instructions for each product, search via www.regin.se.

***Part II* Installation**

Table of contents

Part II Installation

Chapter 5 Installation preparations	18
Using labels	18
Configuration	18
Setting the dipswitches in RU (only models without display)	19
RU-models with display	19
Chapter 6 Installation	20
Mounting	20
Mounting of RU	20
Mounting of RCP	21
Wiring	22
Wiring for RU-...	23
Wiring for RCP100 / RCP100T / RCP100L	24
Wiring for RCP100F / RCP100FT / RCP100FL	30
Wiring for RCP200 / RCP200T / RCP200L	36
Wiring for RCP200F / RCP200FT / RCP200FL	41
Chapter 7 Commissioning	46
Troubleshooting	46

Chapter 5 Installation preparations

Using labels

On the back of the units' electronics cassette, there is a set of labels which makes it easier to install large numbers of Maxi controllers. By using the labels as carriers of information for the installation engineer, much time will be saved and you can keep wiring errors at a minimum.



Figure 1. Label on the back of the RCP-controller

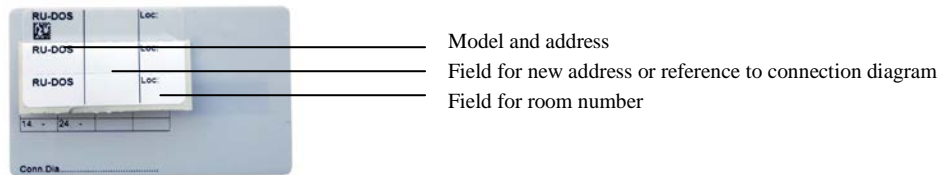

Figure 2. Label on the back of the RU-unit

The three-piece label can be split and the parts can be fastened to the installation drawing and the bottom plate of the controller. The label carries information on the communication address etc., and has a note area where you can enter a reference number to the connection diagram.

If you want to configure the RCP, it may be better to do this before sending the cassette to the installation site. For more information about configuration, see the chapter *Configuration*.

The bottom plates with location and wiring information can be sent separately to the installation site for electric installation.

Configuration

The RCP-controllers are configured using Regio tool[®]. For more information, see the manual for Regio tool[®]. Some settings may also have to be made in the RU-unit. RU-models without display have dipswitches that should be set, see the section *Dipswitches* below.

The computer with Regio tool[®] is connected to the bottom plate using E-cable. E-cable is connected to terminal 41(A) & 40(B). 230 V AC is connected to L1 and N3.

Setting the dipswitches in RU (only models without display)

RU-models without display have four dipswitches (SW1-4) for setting basic functions. They are found on the back of the electronics cassette.



Figure 3. Dipswitches

SW1-2

Basic setpoint (°C)	SW1	SW2
20	OFF	OFF
22 (FS)	OFF	ON
24	ON	OFF
26	ON	ON

Table 3. Setting of basic heating setpoint with dipswitch SW1 and SW2

See also the chapter *Setpoint calculation* for setting of SW1-2.

SW3

Occupied is the preset operating mode, SW3: OFF (FS). If you want the preset operating mode to be Stand-by, set SW3 in mode ON. For more information, see the chapter *Operating modes*.

SW4

Not used.

RU-models with display

There are no dipswitches in RU-models with display. For these models, the corresponding settings are made in the parameter menu in the display or using Regio tool[®], see the chapter *Display handling*.

Chapter 6 Installation

Installation should be done by a professional installer. Since the RCP-unit is powered by 230 V AC, it must be handled with great care. Always switch the power off before removing the cover and electronics cassette from the bottom plate.

Mounting

Mounting of RU

Place the controller in a location that has a temperature representative for the room. A suitable location is approx. 1.6 m above floor level in a place with unobstructed air circulation. Remove the frame by depressing the locking tab in the lower edge of the cover with a screwdriver. See figure 4.

Then prize out the electronics cassette using the four rectangular screwdriver slots and levering against the edge of the bottom plate. See figure 5. **Note:** Take care not to damage the electronics when inserting the screwdriver into the slots.

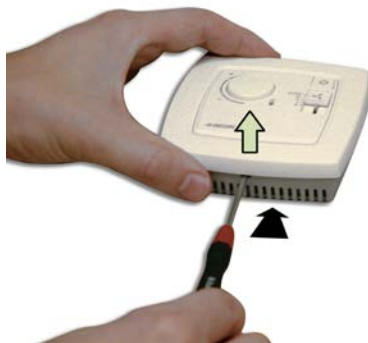

Figure 4.

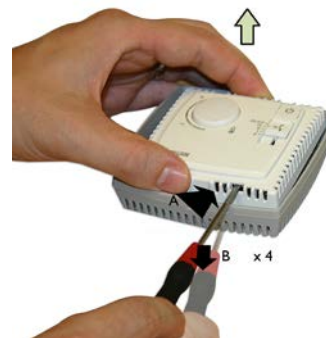

Figure 5.

The bottom plate with terminals has a number of fixing hole combinations. Select suitable holes and screw the bottom plate onto the wall or connection box, so that the arrows on the bottom plate point upwards. Do not tighten the screws too hard!

With surface-mounted cabling, break out suitable holes from the marks in the plastic.

Mounting of RCP

RCP is mounted in the ceiling void, on a junction box plate, or on a DIN-rail. The form factor of the casing is EURO norm, which makes it fit into a standard EURO norm cabinet.

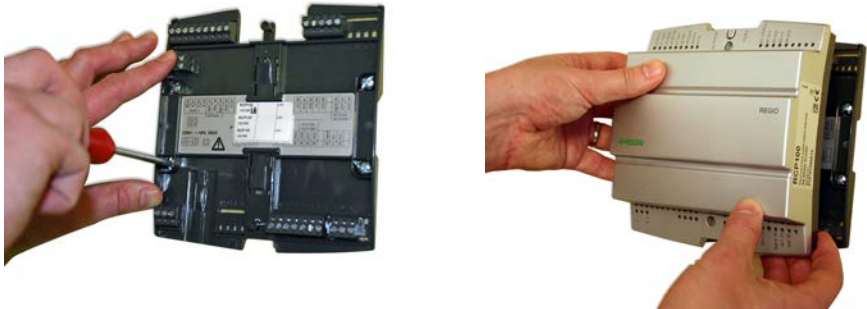

Figure 6. Mounting of RCP in the ceiling void

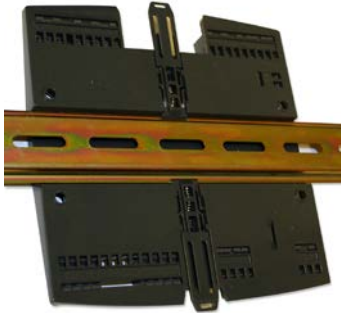

Figure 7. Mounting of RCP on a DIN-rail

Wiring

The figures below show the location of terminals. The connection diagrams and tables on the following pages show the wiring for the RU- and RCP-models.



Figure 7. RU bottom plate with location of terminals

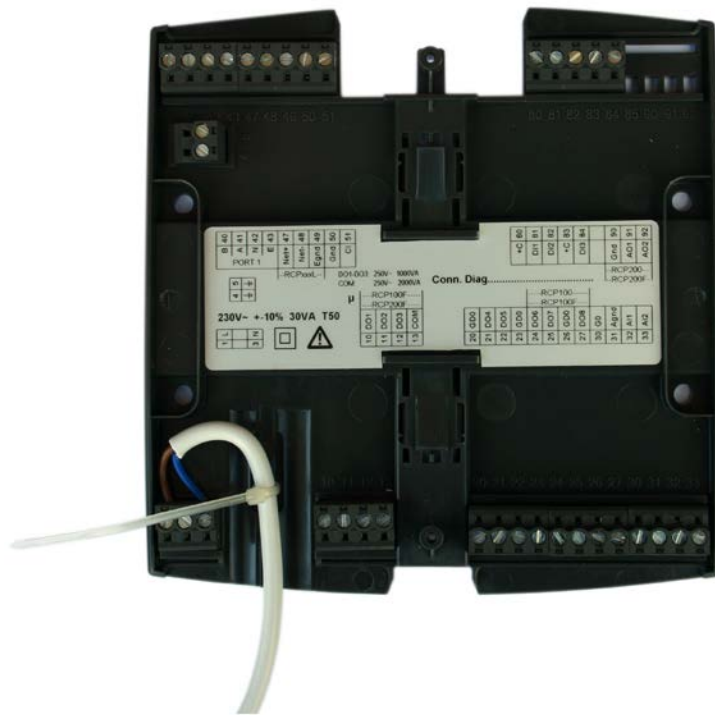
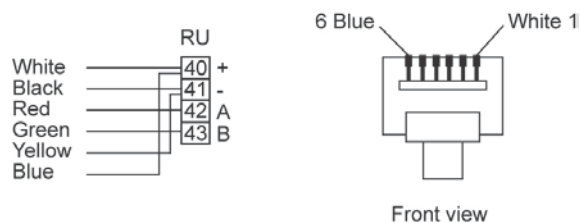

Figure 8. RCP bottom plate with location of terminals, and locking of the line voltage cable

Wiring for RU-...

RU-connection with modular cable with RJ12 fast connector (own production). The maximum cable length is 30 m.



RU-connection with Regin's cables RU-CBL3 (3 m) or RU-CBL10 (10 m) with RJ12 fast connector.

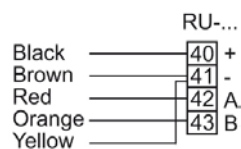

Terminal	Designation	Operation
10-33		No function
40	+5V	Power supply from RCP
41	N (0V)	Power supply from RCP
42	A	RU-Bus A
43	B	RU-Bus B

Table 4.

Wiring for RCP100 / RCP100T / RCP100L

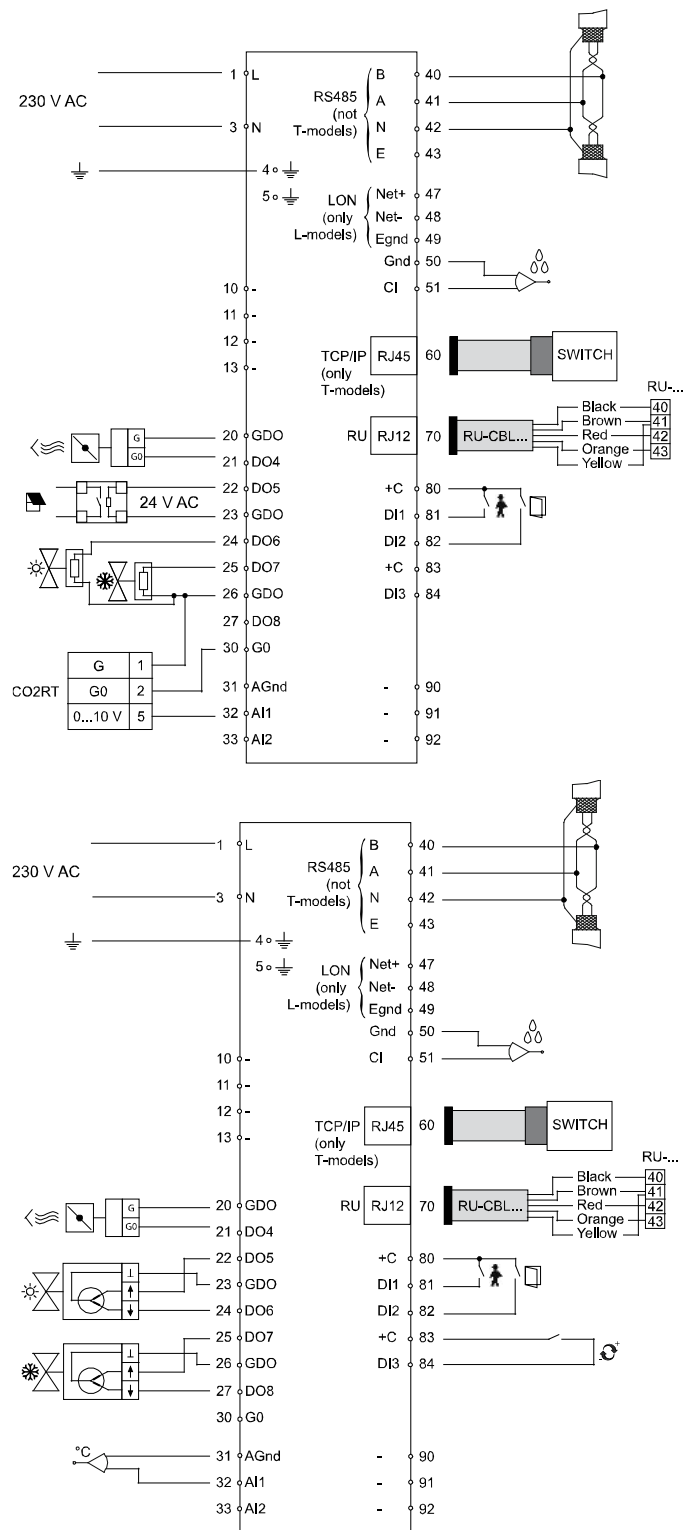

Figure 9. Connection diagrams for RCP100, RCP100T and RCP100L

Terminal	Designation	Operation	
1	L	Line	230 V AC-connection
3	N	Neutral	
4		EMI ground, yellow-green conductor	
5		EMI ground	
10-13		No function	
20	GDO	24 V AC out common for DO4-DO5.	Terminals 20, 23 and 26 are connected internally, max total load 12 VA.
21	DO4	Digital output 4, 24 V AC-output. For forced ventilation (FS). Wiring for 24 V AC-loads: 24 V AC actuator is connected between terminal 21 and terminal 20, GDO. Alternatives: <ul style="list-style-type: none"> - Thermal actuator, heating - Thermal actuator, cooling - Three-point actuator heating increase - Three-point actuator heating decrease - Three-point actuator cooling increase - Three-point actuator cooling decrease - Lighting control - Blind in - Blind out - Sum alarm - Sum alarm A - Sum alarm B 	
22	DO5	Digital output 5, 24 V AC-output. Not configured for use (FS). Wiring for 24 V AC-loads: 24 V AC actuator is connected between terminal 22 and terminal 20, GDO. Alternatives: <ul style="list-style-type: none"> - Forced ventilation - Thermal actuator, heating - Thermal actuator, cooling - Three-point actuator heating increase - Three-point actuator heating decrease - Three-point actuator cooling increase - Three-point actuator cooling decrease - Lighting control - Blind in - Blind out - Sum alarm - Sum alarm A - Sum alarm B 	
23	GDO	24 V AC out common for DO6-7.	Terminals 20, 23 and 26 are connected internally, max total load 12 VA.

24	DO6	<p>Digital output 6, 24 V AC-output. Thermal actuator, heating.</p> <p>Wiring for 24 V AC-loads: 24 V AC actuator is connected between terminal 24 and terminal 23, GDO.</p> <p>Alternatives:</p> <ul style="list-style-type: none"> - Forced ventilation - Thermal actuator, cooling - Three-point actuator heating increase - Three-point actuator heating decrease - Three-point actuator cooling increase - Three-point actuator cooling decrease - Lighting control - Blind in - Blind out - Sum alarm - Sum alarm A - Sum alarm B 	
25	DO7	<p>Digital output 7, 24 V AC-output. Thermal actuator, cooling.</p> <p>Wiring for 24 V AC-loads: 24 V AC actuator is connected between terminal 25 and terminal 23, GDO.</p> <p>Alternatives:</p> <ul style="list-style-type: none"> - Forced ventilation - Thermal actuator, heating - Three-point actuator heating increase - Three-point actuator heating decrease - Three-point actuator cooling increase - Three-point actuator cooling decrease - Lighting control - Blind in - Blind out - Sum alarm - Sum alarm A - Sum alarm B 	
26	GDO	24 V AC out for DO8.	Terminals 20, 23 and 26 are connected internally, max total load 12 VA.

27	DO8	<p>Digital output 8, 24 V AC-output. Not configured for use (FS).</p> <p>Wiring for 24 V AC-loads: 24 V AC actuator is connected between terminal 27 and terminal 23, GDO.</p> <p>Alternatives:</p> <ul style="list-style-type: none"> - Forced ventilation - Thermal actuator, heating - Three-point actuator heating increase - Three-point actuator heating decrease - Three-point actuator cooling increase - Three-point actuator cooling decrease - Lighting control - Blind in - Blind out - Sum alarm - Sum alarm A - Sum alarm B 	
30	G0	<p>0 V AC.</p> <ol style="list-style-type: none"> 1. Normally used as reference ground for valve actuators and external equipment. 2. Can also be used for connecting 24 V AC external power supply to DO4 – DO8, if the available power on GDO is not enough. The power supply's 0 V is connected to terminal 30, an actuator is connected between the power supply's 24 V AC and each respective digital output. 	
31	AGnd	Analogue ground	
32	AI1	<p>Analogue input 1. Not configured for use (FS).</p> <p>Alternatives:</p> <ul style="list-style-type: none"> - External room temperature sensor (PT1000) - Change-over sensor (PT1000) - Outdoor temperature sensor (PT1000) - Condensation detector (0...10 V) - CO₂-detector (0...10 V) - Humidity sensor (0...10 V) <p>Wiring for 0...10 V-sensor: Power supply to analogue sensors (humidity, CO₂) is connected so the sensor's 24 V AC (G0) is connected to terminal 30 (G0) and 24 V AC (G) to terminal 26 (GDO). The sensor's analogue output signal 0...10 V is connected to terminal 32.</p> <p>Wiring for PT1000-element: The sensor is connected between terminals 32 and 31, AGnd.</p>	

33	AI2	<p>Analogue input 2.</p> <p>For switching between heating and cooling on a two-pipe system (Change-over). PT1000-sensor is connected between terminals 33 and 31, AGnd. (FS)</p> <p>Alternatives:</p> <ul style="list-style-type: none"> - External room temperature sensor (PT1000) - Outdoor temperature sensor (PT1000) - Condensation detector (0...10 V) - CO₂-transmitter (0...10 V) - Humidity sensor (0...10 V) <p>Wiring for 0...10 V-sensor:</p> <p>Power supply to analogue sensors (humidity, CO₂) is connected so the sensor's 24 V AC (G0) is connected to terminal 30 (G0) and 24 V AC (G) to terminal 26 (GDO).</p> <p>The sensor's analogue output signal 0...10 V is connected to terminal 33.</p> <p>Wiring for PT1000-element:</p> <p>The sensor is connected between terminals 33 and 31, AGnd.</p>	
40	B		EXOnline-connection, not T-models
41	A		
42	N	The 0 V reference. This should be connected to the screen of the communication cable, which in turn should be grounded at one point only.	
43	E		
47	Net+		LON-connection (only L-models)
48	Net-		
49	EGnd		
50	Gnd		
51	CI	Regin's condensation detector, KG-A/1. The sensor is connected between terminals 51 and 50, Gnd.	
60	TCP/IP		TCP/IP-connection, only T-models
70	RU	Room unit	See the section <i>Wiring for RU-...</i>
80	+C	24 V DC out common for DI1 and DI2.	
81	DI1	<p>Occupancy detector (FS), potential-free, NO. Open contact corresponds to absence.</p> <p><i>See also the section Occupancy detector in the chapter Operating modes.</i></p> <p>Wiring:</p> <p>Potential-free contact is connected between terminals 81 and 80, +C.</p> <p>Alternatives:</p> <ul style="list-style-type: none"> - Window contact, potential-free, NO. Open contact corresponds to closed window. - Condensation detector, potential-free, NO. Open contact corresponds to no condensation. - Change-over sensor, potential-free, NO. Open contact corresponds to heating demand. 	See Regio tool [®] for configuration of NO/NC. The factory setting is normally open (NO) contacts, but the contacts can be configured to NC.

82	DI2	<p>Window contact, potential-free, NO. Open contact corresponds to closed window (FS).</p> <p>Wiring: Potential-free contact is connected between terminals 82 and 80, +C.</p> <p>Alternatives:</p> <ul style="list-style-type: none"> - Condensation detector, potential-free, NO. Open contact corresponds to no condensation. - Occupancy detector, potential-free, NO. Open contact corresponds to absence. - Change-over sensor, potential-free, NO. Open contact corresponds to heating demand. 	See Regio tool [®] for configuration of NO/NC. The factory setting is normally open (NO) contacts, but the contacts can be configured to NC.
83	+C	24 V DC out common for DI3.	
84	DI3	<p>Change-over, potential-free, NO. Open contact corresponds to heating demand (FS).</p> <p>For switching between heating and cooling on a two-pipe system.</p> <p>Wiring: Potential-free contact is connected between terminals 84 and 83, +C.</p> <p>Alternatives:</p> <ul style="list-style-type: none"> - Window contact, potential-free, NO. Open contact corresponds to closed window. - Condensation detector, potential-free, NO. Open contact corresponds to no condensation. - Occupancy detector, potential-free, NO. Open contact corresponds to absence. 	See Regio tool [®] for configuration of NO/NC. The factory setting is normally open (NO) contacts, but the contacts can be configured to NC.
90-92		No function	

Table 5. I/O connection terminals for RCP100, RCP100T and RCP100L

Wiring for RCP100F / RCP100FT / RCP100FL

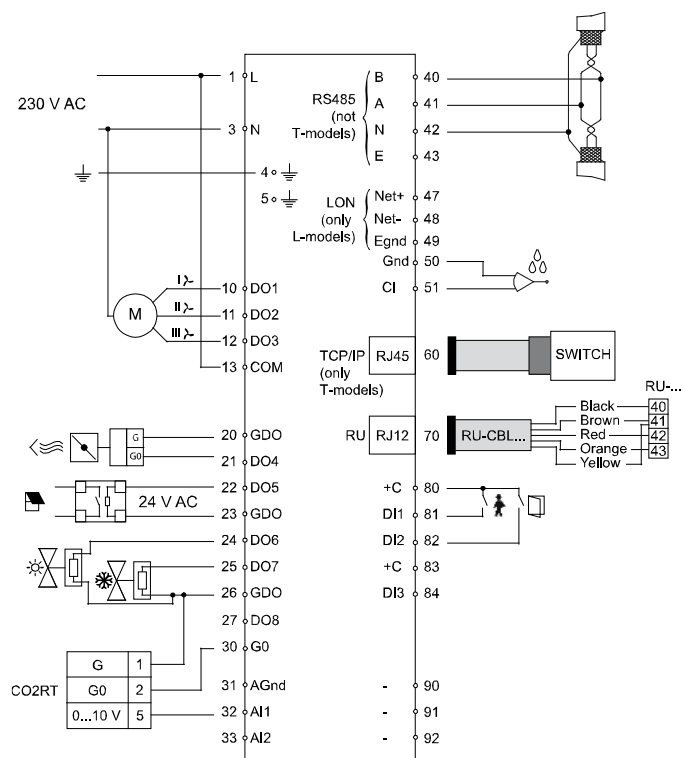

Figure 10. Connection diagram for RCP100F, RCP100FT and RCP100FL

Terminal	Designation	Operation	
1	L	Line	230 V AC-connection
3	N	Neutral	
4		EMI ground, yellow-green conductor	
5		EMI ground	
10	DO1	For fan control, low speed. 230 V AC output. Fan is connected between terminals 10 and N (Neutral).	
11	DO2	For fan control, medium speed. 230 V AC output. Fan is connected between terminals 11 and N (Neutral).	
12	DO3	For fan control, high speed. 230 V AC output. Fan is connected between terminals 12 and N (Neutral).	
13	COM	Connection of L (Line)	Common pole for DO1-3
20	GDO	24 V AC out common for DO4-DO5.	Terminals 20, 23 and 26 are connected internally, max total load 12 VA.

21	DO4	<p>Digital output 4, 24 V AC-output. For forced ventilation (FS).</p> <p>Wiring for 24 V AC-loads: 24 V AC actuator is connected between terminal 21 and terminal 20, GDO.</p> <p>Alternatives:</p> <ul style="list-style-type: none"> - Thermal actuator, heating - Thermal actuator, cooling - Three-point actuator heating increase - Three-point actuator heating decrease - Three-point actuator cooling increase - Three-point actuator cooling decrease - Lighting control - Blind in - Blind out - Sum alarm - Sum alarm A - Sum alarm B 	
22	DO5	<p>Digital output 5, 24 V AC-output Not configured for use (FS).</p> <p>Wiring for 24 V AC-loads: 24 V AC actuator is connected between terminal 22 and terminal 20, GDO.</p> <p>Alternatives:</p> <ul style="list-style-type: none"> - Forced ventilation - Thermal actuator, heating - Thermal actuator, cooling - Three-point actuator heating increase - Three-point actuator heating decrease - Three-point actuator cooling increase - Three-point actuator cooling decrease - Lighting control - Blind in - Blind out - Sum alarm - Sum alarm A - Sum alarm B 	
23	GDO	24 V AC out common for DO6-7.	Terminals 20, 23 and 26 are connected internally, max total load 12 VA.

24	DO6	<p>Digital output 6, 24 V AC-output. Thermal actuator, heating.</p> <p>Wiring for 24 V AC-loads: 24 V AC actuator is connected between terminal 24 and terminal 23, GDO.</p> <p>Alternatives:</p> <ul style="list-style-type: none"> - Forced ventilation - Thermal actuator, cooling - Three-point actuator heating increase - Three-point actuator heating decrease - Three-point actuator cooling increase - Three-point actuator cooling decrease - Lighting control - Blind in - Blind out - Sum alarm - Sum alarm A - Sum alarm B 	
25	DO7	<p>Digital output 7, 24 V AC-output. Thermal actuator, cooling.</p> <p>Wiring for 24 V AC-loads: 24 V AC actuator is connected between terminal 25 and terminal 23, GDO.</p> <p>Alternatives:</p> <ul style="list-style-type: none"> - Forced ventilation - Thermal actuator, heating - Three-point actuator heating increase - Three-point actuator heating decrease - Three-point actuator cooling increase - Three-point actuator cooling decrease - Lighting control - Blind in - Blind out - Sum alarm - Sum alarm A - Sum alarm B 	
26	GDO	24 V AC out for DO8.	Terminals 20, 23 and 26 are connected internally, max total load 12 VA.

27	DO8	<p>Digital output 8, 24 V AC-output. Not configured for use (FS).</p> <p>Wiring for 24 V AC-loads: 24 V AC actuator is connected between terminal 27 and terminal 23, GDO.</p> <p>Alternatives:</p> <ul style="list-style-type: none"> - Forced ventilation - Thermal actuator, heating - Three-point actuator heating increase - Three-point actuator heating decrease - Three-point actuator cooling increase - Three-point actuator cooling decrease - Lighting control - Blind in - Blind out - Sum alarm - Sum alarm A - Sum alarm B 	
30	G0	<p>0 V AC.</p> <ol style="list-style-type: none"> 1. Normally used as reference ground for valve actuators and external equipment. 2. Can also be used for connecting 24 V AC external power supply to DO4 – DO8, if the available power on GDO is not enough. The power supply's 0 V is connected to terminal 30, an actuator is connected between the power supply's 24 V AC and each respective digital output. 	
31	AGnd	Analogue ground	
32	AI1	<p>Analogue input 1. Not configured for use (FS).</p> <p>Alternatives:</p> <ul style="list-style-type: none"> - External room temperature sensor (PT1000) - Change-over sensor (PT1000) - Outdoor temperature sensor (PT1000) - Condensation detector (0...10 V) - CO₂-transmitter (0...10 V) - Humidity sensor (0...10 V) <p>Wiring for 0...10 V sensor: Power supply to analogue sensors (humidity, CO₂) is connected so the sensor's 24 V AC (G0) is connected to terminal 30 (G0) and 24 V AC (G) to terminal 26 (GDO). The sensor's analogue output signal 0...10 V is connected to terminal 32.</p> <p>Wiring for PT1000-element: The sensor is connected between terminals 32 and 31, AGnd.</p>	

33	AI2	<p>Analogue input 2.</p> <p>For switching between heating and cooling on a two-pipe system (Change-over). PT1000-sensor is connected between terminals 33 and 31, AGnd. (FS)</p> <p>Alternatives:</p> <ul style="list-style-type: none"> - External room temperature sensor (PT1000) - Outdoor temperature sensor (PT1000) - Condensation detector (0...10 V) - CO₂-transmitter (0...10 V) - Humidity sensor (0...10 V) <p>Wiring for 0...10 V sensor:</p> <p>Power supply to analogue sensors (humidity, CO₂) is connected so the sensor's 24 V AC (G0) is connected to terminal 30 (G0) and 24 V AC (G) to terminal 26 (GDO).</p> <p>The sensor's analogue output signal 0...10 V is connected to terminal 33.</p> <p>Wiring for PT1000-element</p> <p>The sensor is connected between terminals 33 and 31, AGnd.</p>	
40	B		EXOnline-connection, not T-models
41	A		
42	N	The 0 V reference. This should be connected to the screen of the communication cable, which in turn should be grounded at one point only.	
43	E		
47	Net+		LON-connection (only L-models)
48	Net-		
49	EGnd		
50	Gnd		
51	CI	Regin's condensation detector, KG-A/1. The sensor is connected between terminals 51 and 50, Gnd.	
60	TCP/IP		TCP/IP-connection, only T-models
70	RU	Room unit	See the section <i>Wiring for RU...</i>
80	+C	24 V DC out common for DI1 and DI2.	
81	DI1	<p>Occupancy detector (FS), potential-free, NO. Open contact corresponds to absence.</p> <p><i>See also the section Occupancy detector in the chapter Operating modes.</i></p> <p>Wiring:</p> <p>Potential-free contact is connected between terminals 81 and 80, +C.</p> <p>Alternatives:</p> <ul style="list-style-type: none"> - Window contact, potential-free, NO. Open contact corresponds to closed window. - Condensation detector, potential-free, NO. Open contact corresponds to no condensation. - Change-over sensor, potential-free, NO. Open contact corresponds to heating demand. 	See Regio tool [®] for configuration of NO/NC. The factory setting is normally open (NO) contacts, but the contacts can be configured to NC.

82	DI2	<p>Window contact, potential-free, NO. Open contact corresponds to closed window (FS).</p> <p>Wiring: Potential-free contact is connected between terminals 82 and 80, +C.</p> <p>Alternatives:</p> <ul style="list-style-type: none"> - Condensation detector, potential-free, NO. Open contact corresponds to no condensation. - Occupancy detector, potential-free, NO. Open contact corresponds to absence. - Change-over sensor, potential-free, NO. Open contact corresponds to heating demand. 	See Regio tool [®] for configuration of NO/NC. The factory setting is normally open (NO) contacts, but the contacts can be configured to NC.
83	+C	24 V DC out common for DI3.	
84	DI3	<p>Change-over, potential-free, NO. Open contact corresponds to heating demand (FS).</p> <p>For switching between heating and cooling on a two-pipe system.</p> <p>Wiring: Potential-free contact is connected between terminals 84 and 83, +C.</p> <p>Alternatives:</p> <ul style="list-style-type: none"> - Window contact, potential-free, NO. Open contact corresponds to closed window. - Condensation detector, potential-free, NO. Open contact corresponds to no condensation. - Occupancy detector, potential-free, NO. Open contact corresponds to absence. 	See Regio tool [®] for configuration of NO/NC. The factory setting is normally open (NO) contacts, but the contacts can be configured to NC.
90-92		No function	

Table 6. I/O connection terminals for RCP100F, RCP100FT and RCP100FL

Wiring for RCP200 / RCP200T / RCP200L

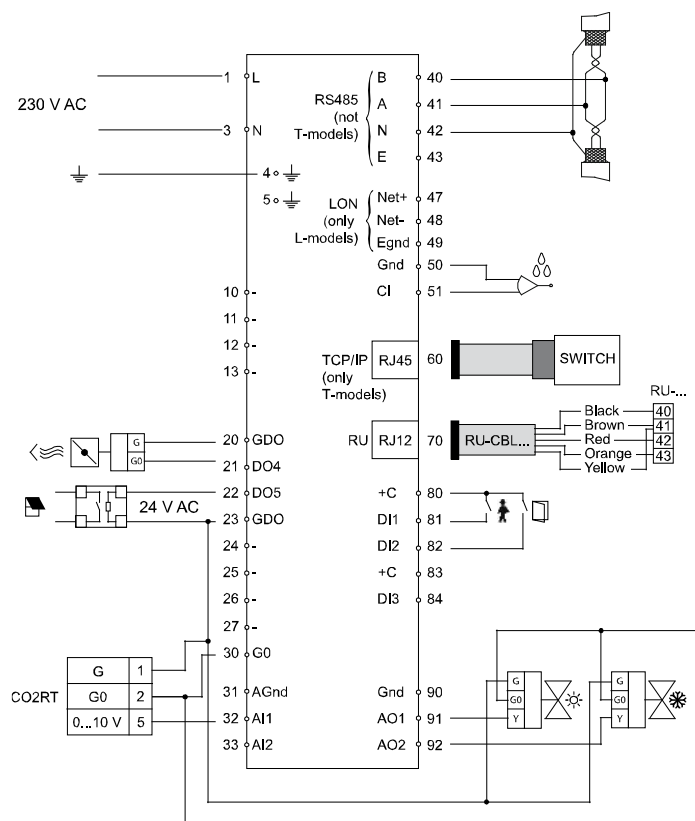

Figure 11. Connection diagram for RCP200, RCP200T and RCP200L

Terminal	Designation	Operation	
1	L	Line	230 V AC-connection
3	N	Neutral	
4		EMI ground, yellow-green conductor	
5		EMI ground	
10-13		No function	
20	GDO	24 V AC out common for DO.	Terminals 20 and 23 are connected internally, max total load 12 VA.

21	DO4	<p>Digital output 4, 24 V AC-output. For forced ventilation (FS).</p> <p>Wiring for 24 V AC-loads: 24 V AC actuator is connected between terminal 21 and terminal 20, GDO.</p> <p>Alternatives:</p> <ul style="list-style-type: none"> - Thermal actuator, heating - Thermal actuator, cooling - Three-point actuator heating increase - Three-point actuator heating decrease - Three-point actuator cooling increase - Three-point actuator cooling decrease - Lighting control - Blind in - Blind out - Sum alarm - Sum alarm A - Sum alarm B 	
22	DO5	<p>Digital output 5, 24 V AC-output. Not configured for use (FS).</p> <p>Wiring for 24 V AC-loads: 24 V AC actuator is connected between terminal 22 and terminal 20, GDO.</p> <p>Alternatives:</p> <ul style="list-style-type: none"> - Forced ventilation - Thermal actuator, heating - Thermal actuator, cooling - Three-point actuator heating increase - Three-point actuator heating decrease - Three-point actuator cooling increase - Three-point actuator cooling decrease - Lighting control - Blind in - Blind out - Sum alarm - Sum alarm A - Sum alarm B 	
23	GDO	24 V AC out common for DO.	Terminals 20 and 23 are connected internally, max total load 12 VA.
24-27		No function	
30	G0	<p>0 V AC.</p> <ol style="list-style-type: none"> 1. Normally used as reference ground for valve actuators and external equipment. 2. Can also be used for connecting 24 V AC external power supply to DO4 – DO8, if the available power on GDO is not enough. The power supply's 0 V is connected to terminal 30, an actuator is connected between the power supply's 24 V AC and each respective digital output. 	
31	AGnd	Analogue ground	

32	AI1	<p>Analogue input 1. Not configured for use (FS).</p> <p>Alternatives:</p> <ul style="list-style-type: none"> - External room temperature sensor (PT1000) - Change-over sensor (PT1000) - Outdoor temperature sensor (PT1000) - Condensation detector (0...10 V) - CO₂-transmitter (0...10 V) - Humidity sensor (0...10 V) <p>Wiring for 0...10 V-sensor:</p> <p>Power supply to analogue sensors (humidity, CO₂) is connected so the sensor's 24 V AC (G0) is connected to terminal 30 (G0) and 24 V AC (G) to terminal 26 (GDO).</p> <p>The sensor's analogue output signal 0...10 V is connected to terminal 32.</p> <p>Wiring for PT1000-element:</p> <p>The sensor is connected between terminals 32 and 31, AGnd.</p>	
33	AI2	<p>Analogue input 2. For switching between heating and cooling on a two-pipe system (Change-over). PT1000-sensor is connected between terminals 33 and 31, AGnd. (FS)</p> <p>Alternatives:</p> <ul style="list-style-type: none"> - External room temperature sensor (PT1000) - Outdoor temperature sensor (PT1000) - Condensation detector (0...10 V) - CO₂-transmitter (0...10 V) - Humidity sensor (0...10 V) <p>Wiring for 0...10 V-sensor:</p> <p>Power supply to analogue sensors (humidity, CO₂) is connected so the sensor's 24 V AC (G0) is connected to terminal 30 (G0) and 24 V AC (G) to terminal 26 (GDO).</p> <p>The sensor's analogue output signal 0...10 V is connected to terminal 33.</p> <p>Wiring for PT1000-element:</p> <p>The sensor is connected between terminals 33 and 31, AGnd.</p>	
40	B		EXOnline-connection, not T-models
41	A		
42	N	The 0 V reference. This should be connected to the screen of the communication cable, which in turn should be grounded at one point only.	
43	E		
47	Net+		LON-connection (only L-models)
48	Net-		
49	EGnd		
50	Gnd		
51	CI	Regin's condensation detector, KG-A/1. The sensor is connected between terminals 51 and 50, Gnd.	
60	TCP/IP		TCP-connection, only T-models
70	RU	Room sensor	See the section <i>Wiring for RU-...</i>
80	+C	24 V DC out common for DI1 and DI2	

81	DI1	<p>Digital input 1, 24 V DC.</p> <p>Occupancy detector (FS), potential-free, NO. Open contact corresponds to absence.</p> <p><i>See also the section Occupancy detector in the chapter Operating modes.</i></p> <p>Wiring:</p> <p>Potential-free contact is connected between terminals 81 and 80, +C.</p> <p>Alternatives:</p> <ul style="list-style-type: none"> - Window contact, potential-free, NO. Open contact corresponds to closed window. - Condensation detector, potential-free, NO. Open contact corresponds to no condensation. - Change-over sensor, potential-free, NO. Open contact corresponds to heating demand. 	<p>See Regio tool[®] for configuration of NO/NC. The factory setting is normally open (NO) contacts, but the contacts can be configured to NC.</p>
82	DI2	<p>Digital input 2, 24 V DC.</p> <p>Window contact, potential-free, NO. Open contact corresponds to closed window. (FS)</p> <p>Wiring:</p> <p>Potential-free contact is connected between terminals 82 and 80, +C.</p> <p>Alternatives:</p> <ul style="list-style-type: none"> - Condensation detector, potential-free, NO. Open contact corresponds to no condensation. - Occupancy detector, potential-free, NO. Open contact corresponds to absence. - Change-over sensor, potential-free, NO. Open contact corresponds to heating demand. 	<p>See Regio tool[®] for configuration of NO/NC. The factory setting is normally open (NO) contacts, but the contacts can be configured to NC.</p>
83	+C	24 V DC out common for DI3	
84	DI3	<p>Digital input 3, 24 V DC.</p> <p>Not configured for use (FS).</p> <p>Wiring:</p> <p>Potential-free contact is connected between terminals 84 and 83, +C.</p> <p>Alternatives:</p> <ul style="list-style-type: none"> - Window contact, potential-free, NO. Open contact corresponds to closed window. - Condensation detector, potential-free, NO. Open contact corresponds to no condensation. - Occupancy detector, potential-free, NO. Open contact corresponds to absence. - Change-over, potential-free, NO. Open contact corresponds to heating demand. For switching between heating and cooling on a two-pipe system. 	<p>See Regio tool[®] for configuration of NO/NC. The factory setting is normally open (NO) contacts, but the contacts can be configured to NC.</p>
90	Gnd	Reference ground for AO1-AO2 when high-ohm loads are used and maximal accuracy is desired.	
91	AO1	<p>Analogue output 1.</p> <p>Valve actuator, 0...10 V DC, max 5 mA. Control state: heating (FS).</p> <p>Wiring:</p> <p>Valve actuator is connected between terminals 91 and 30, G0.</p> <p>Alternative:</p> <ul style="list-style-type: none"> - Valve actuator, 0...10 V DC, max 5 mA. Control state: cooling. 	

92	AO2	<p>Analogue output 2. Valve actuator, 0...10 V DC, max 5 mA. Control state: cooling.</p> <p>Wiring: Valve actuator is connected between terminals 92 and 30, G0.</p> <p>Alternative: - Valve actuator, 0...10 V DC, max 5 mA. Control state: heating.</p>	
----	-----	---	--

Table 7. I/O connection terminals for RCP200, RCP200T and RCP200L

Wiring for RCP200F / RCP200FT / RCP200FL

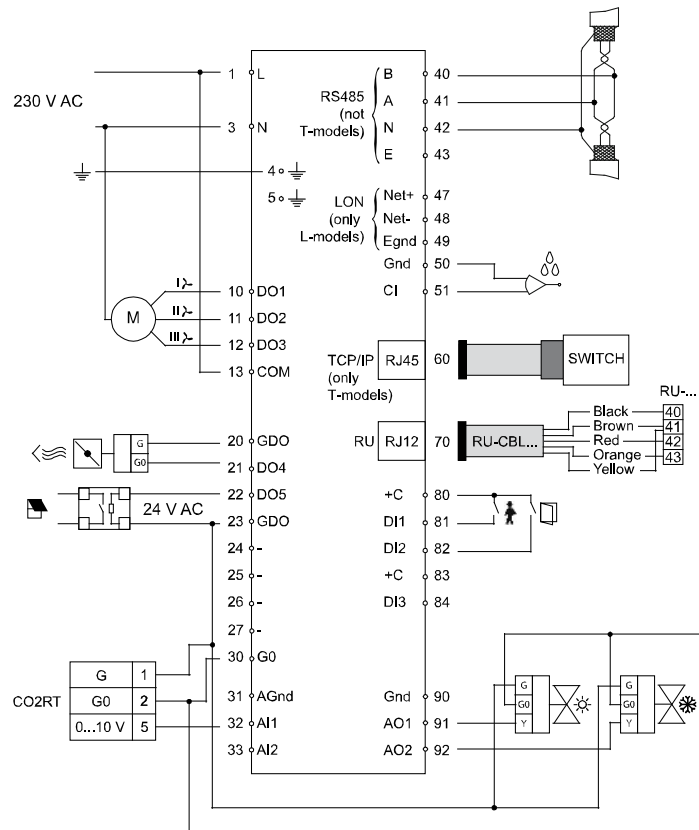

Figure 12. Connection diagram for RCP200F, RCP200FT and RCP200FL

Terminal	Designation	Operation	
1	L	Line	230 V AC-connection
3	N	Neutral	
4		EMI ground, yellow-green conductor	
5		EMI ground	
10	DO1	For fan control, low speed. 230 V AC output. Fan is connected between terminals 10 and N (Neutral).	
11	DO2	For fan control, medium speed. 230 V AC output. Fan is connected between terminals 11 and N (Neutral).	
12	DO3	For fan control, high speed. 230 V AC output. Fan is connected between terminals 12 and N (Neutral).	
13	COM	Connection of L (Line)	Common pole for DO1-3
20	GDO	24 V AC out common for DO.	Terminals 20 and 23 are connected internally, max total load 12 VA.

21	DO4	<p>Digital output 4, 24 V AC-output. For forced ventilation (FS).</p> <p>Wiring for 24 V AC-loads: 24 V AC actuator is connected between terminal 21 and terminal 20, GDO.</p> <p>Alternatives:</p> <ul style="list-style-type: none"> - Thermal actuator, heating - Thermal actuator, cooling - Three-point actuator heating increase - Three-point actuator heating decrease - Three-point actuator cooling increase - Three-point actuator cooling decrease - Lighting control - Blind in - Blind out - Sum alarm - Sum alarm A - Sum alarm B 	
22	DO5	<p>Digital output 5, 24 V AC-output. Not configured for use (FS).</p> <p>Wiring for 24 V AC-loads: 24 V AC actuator is connected between terminal 22 and terminal 20, GDO.</p> <p>Alternatives:</p> <ul style="list-style-type: none"> - Forced ventilation - Thermal actuator, heating - Thermal actuator, cooling - Three-point actuator heating increase - Three-point actuator heating decrease - Three-point actuator cooling increase - Three-point actuator cooling decrease - Lighting control - Blind in - Blind out - Sum alarm - Sum alarm A - Sum alarm B 	
23	GDO	24 V AC out common for DO.	Terminals 20 and 23 are connected internally, max total load 12 VA.
24-27		No function	
30	G0	<p>0 V AC.</p> <ol style="list-style-type: none"> 1. Normally used as reference ground for valve actuators and external equipment. 2. Can also be used for connecting 24 V AC external power supply to DO4 – DO8, if the available power on GDO is not enough. The power supply's 0 V is connected to terminal 30, an actuator is connected between the power supply's 24 V AC and each respective digital output. 	
31	AGnd	Analogue ground	

32	AI1	<p>Analogue input 1.</p> <p>Not configured for use (FS).</p> <p>Alternatives:</p> <ul style="list-style-type: none"> - External room temperature sensor (PT1000) - Change-over sensor (PT1000) - Outdoor temperature sensor (PT1000) - Condensation detector (0...10 V) - CO₂-transmitter (0...10 V) - Humidity sensor (0...10 V) <p>Wiring for 0...10 V-sensor:</p> <p>Power supply to analogue sensors (humidity, CO₂) is connected so the sensor's 24 V AC (G0) is connected to terminal 30 (G0) and 24 V AC (G) to terminal 26 (GDO).</p> <p>The sensor's analogue output signal 0...10 V is connected to terminal 32.</p> <p>Wiring for PT1000-element</p> <p>The sensor is connected between terminals 32 and 31, AGnd.</p>	
33	AI2	<p>Analogue input 2.</p> <p>For switching between heating and cooling on a two-pipe system (Change-over). PT1000-sensor is connected between terminals 33 and 31, AGnd. (FS)</p> <p>Alternatives:</p> <ul style="list-style-type: none"> - External room temperature sensor (PT1000) - Outdoor temperature sensor (PT1000) - Condensation detector (0...10 V) - CO₂-transmitter (0...10 V) - Humidity sensor (0...10 V) <p>Wiring for 0...10 V-sensor:</p> <p>Power supply to analogue sensors (humidity, CO₂) is connected so the sensor's 24 V AC (G0) is connected to terminal 30 (G0) and 24 V AC (G) to terminal 26 (GDO).</p> <p>The sensor's analogue output signal 0...10 V is connected to terminal 33.</p> <p>Wiring for PT1000-element</p> <p>The sensor is connected between terminals 33 and 31, AGnd</p>	
40	B		EXOline-connection, not T-models
41	A		
42	N	The 0 V reference. This should be connected to the screen of the communication cable, which in turn should be grounded at one point only.	
43	E		
47	Net+		LON-connection (only L-models)
48	Net-		
49	EGnd		
50	Gnd		
51	CI	Regin's condensation detector, KG-A/1. The sensor is connected between terminals 51 and 50, Gnd.	
60	TCP/IP		TCP-connection, only T-models
70	RU	Room sensor	See the section <i>Wiring for RU-...</i>
80	+C	24 V DC out common for DI1 and DI2	

81	DI1	<p>Digital input 1, 24 V DC.</p> <p>Occupancy detector (FS), potential-free, NO. Open contact corresponds to absence.</p> <p><i>See also the section Occupancy detector in the chapter Operating modes.</i></p> <p>Wiring:</p> <p>Potential-free contact is connected between terminals 81 and 80, +C.</p> <p>Alternatives:</p> <ul style="list-style-type: none"> - Window contact, potential-free, NO. Open contact corresponds to closed window. - Condensation detector, potential-free, NO. Open contact corresponds to no condensation. - Change-over sensor, potential-free, NO. Open contact corresponds to heating demand. 	<p>See Regio tool[®] for configuration of NO/NC. The factory setting is normally open (NO) contacts, but the contacts can be configured to NC.</p>
82	DI2	<p>Digital input 2, 24 V DC.</p> <p>Window contact, potential-free, NO. Open contact corresponds to closed window (FS).</p> <p>Wiring:</p> <p>Potential-free contact is connected between terminals 82 and 80, +C.</p> <p>Alternatives:</p> <ul style="list-style-type: none"> - Condensation detector, potential-free, NO. Open contact corresponds to no condensation. - Occupancy detector, potential-free, NO. Open contact corresponds to absence. - Change-over sensor, potential-free, NO. Open contact corresponds to heating demand. 	<p>See Regio tool[®] for configuration of NO/NC. The factory setting is normally open (NO) contacts, but the contacts can be configured to NC.</p>
83	+C	24 V DC out common for DI3	
84	DI3	<p>Digital input 3, 24 V DC.</p> <p>Not configured for use (FS).</p> <p>Wiring:</p> <p>Potential-free contact is connected between terminals 84 and 83, +C.</p> <p>Alternatives:</p> <ul style="list-style-type: none"> - Window contact, potential-free, NO. Open contact corresponds to closed window. - Condensation detector, potential-free, NO. Open contact corresponds to no condensation. - Occupancy detector, potential-free, NO. Open contact corresponds to absence. - Change-over, potential-free, NO. Open contact corresponds to heating demand. For switching between heating and cooling on a two-pipe system. 	<p>See Regio tool[®] for configuration of NO/NC. The factory setting is normally open (NO) contacts, but the contacts can be configured to NC.</p>
90	Gnd	Reference ground for AO1-AO2 when high-ohm loads are used and maximal accuracy is desired.	
91	AO1	<p>Analogue output 1.</p> <p>Valve actuator, 0...10 V DC, max 5 mA. Control state: heating (FS).</p> <p>Wiring:</p> <p>Valve actuator is connected between terminals 91 and 30, G0.</p> <p>Alternative:</p> <ul style="list-style-type: none"> - Valve actuator, 0...10 V DC, max 5 mA. Control state: cooling. 	

92	AO2	<p>Analogue output 2. Valve actuator, 0...10 V DC, max 5 mA. Control state: cooling.</p> <p>Wiring: Valve actuator is connected between terminals 92 and 30, G0.</p> <p>Alternative: - Valve actuator, 0...10 V DC, max 5 mA. Control state: heating.</p>	
----	-----	---	--

Table 8. I/O connection terminals for RCP200F, RCP200FT and RCP200FL

Chapter 7 Commissioning

The easiest way to set parameters is via Regio tool[®].

Calibration of a measured room temperature should be done under stable conditions.

Troubleshooting

The Hand/Auto function in Regio tool[®] makes it possible to test outputs. The output itself is not affected, only the software object that controls the output. This means that built-in safety functions will not be disregarded.

The controllers have different indications which can be used for troubleshooting, see the section *Indications*.

***Part III* Configuration**

Table of contents

Part III Configuration

<i>Chapter 8</i>	Control states	49
<i>Chapter 9</i>	Operating modes	52
	Different operating modes	52
	Activation of the different operating modes	53
<i>Chapter 10</i>	Setpoint calculation	57
<i>Chapter 11</i>	Actuators	59
<i>Chapter 12</i>	Fan control	60
<i>Chapter 13</i>	Change-over function	61
<i>Chapter 14</i>	Forced ventilation / Condensation detector / Frost protection	62
<i>Chapter 15</i>	Indications	63
	Indications on the RU-units	63
	Indications on the RCP-units	64
<i>Chapter 16</i>	Functions for RU-DOS	65
	Lighting control	65
	Control of blinds	65
	CO ₂ -transmitter	66
	Humidity sensor	66
	Outdoor temperature sensor	66
<i>Chapter 17</i>	Display handling	67
	Display indications	67
	The Select button	68
	The parameter menu	68

Chapter 8 Control states

The controllers can be configured for different control states/control sequences:

- Heating
- Heating or cooling via the change-over function
- Heating/Heating
- Heating/Cooling
- Heating/Cooling with VAV-control and forced supply air function
- Heating/Cooling with VAV-control
- Cooling
- Cooling/Cooling

Heating

In control state Heating, the unit is always a heating controller and controls according to the heating setpoint plus/minus the setpoint displacement. The setpoint can be adjusted in the display or via the setpoint knob.

Heating or cooling via the change-over function

Like control state Heating but with change-over function, i. e. when the change-over input is active, the controller becomes a cooling controller and regulates according to the basic cooling setpoint plus/minus the setpoint displacement. See more in the chapter *Change-over*.

Heating/Heating

Split output signal

In control state Heating/Heating, the unit is always a heating controller and controls according to the basic heating setpoint plus the setpoint displacement. When the controller output signal reaches 50%, it is divided between two actuators. 0...48% of the signal is sent to actuator 1 and 52...100% of the signal is sent to actuator 2. See the figure below.

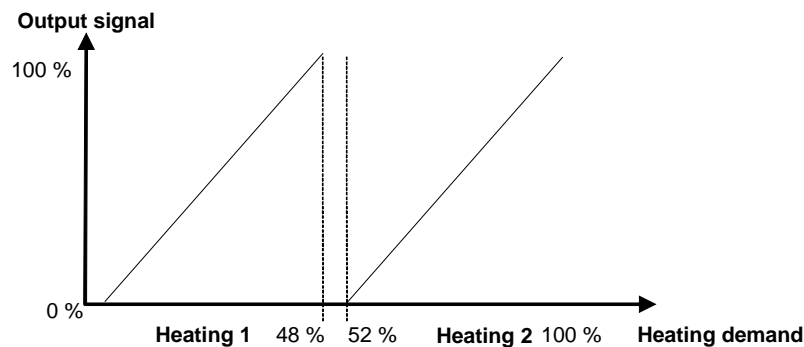

Heating/Cooling

In control state Heating/Cooling, the controller functions as a heating controller when the room temperature is lower than the basic heating setpoint plus half the neutral zone. The neutral zone is the difference in temperature between the heating setpoint and the cooling setpoint. When the room temperature exceeds this limit, the controller becomes a cooling controller. There is a hysteresis of 0.1°C when the controller changes from heating to cooling and vice versa. When the controller is heating, it regulates according to the basic heating setpoint plus the setpoint displacement, and when it is cooling according to the basic cooling setpoint plus the setpoint adjustment.

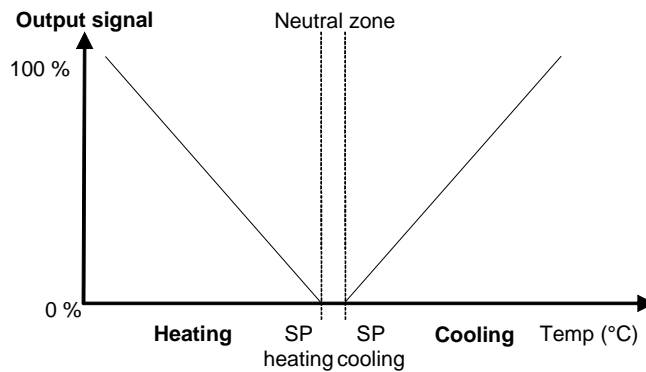

Heating/Cooling with VAV-control and forced supply air function

Like control state Heating/Cooling but the cooling is controlled via a supply air damper (sub-tempered supply air). When the ventilation is forced (See the chapter *Forced ventilation*), the cooling output is set to full cooling (full supply air volume), regardless of what the controller output signal is.

Heating/Cooling with VAV-control

Heating and cooling are controlled in the same way as in the VAV-control above. The damper cannot be forced like above. There is also a function that opens the supply air damper on heating demand. This is normally always required if the heater is placed in the supply air duct, to carry the heat to the room. A maximum limit is set for the opening of the damper on heating demand. The factory setting is zero, which means that the function to open the damper on heating demand is not active. The basic flow can also be set separately.

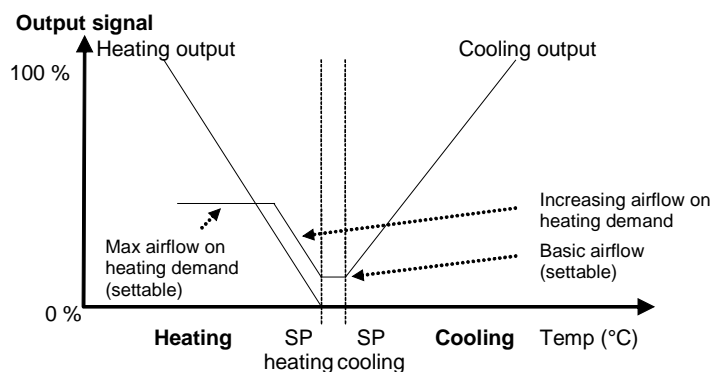

Cooling

In control state Cooling, the unit is always a cooling controller and controls according to the basic cooling setpoint plus the setpoint displacement.

Cooling/Cooling

Split output signal

In control mode Cooling/Cooling, the controller always functions as a cooling controller and controls according to the basic cooling setpoint plus the setpoint displacement. When the controller output signal reaches 50%, it is divided between two actuators. 0...48% of the signal is sent to actuator 1 and 52...100% of the signal is sent to actuator 2. See the figure below.

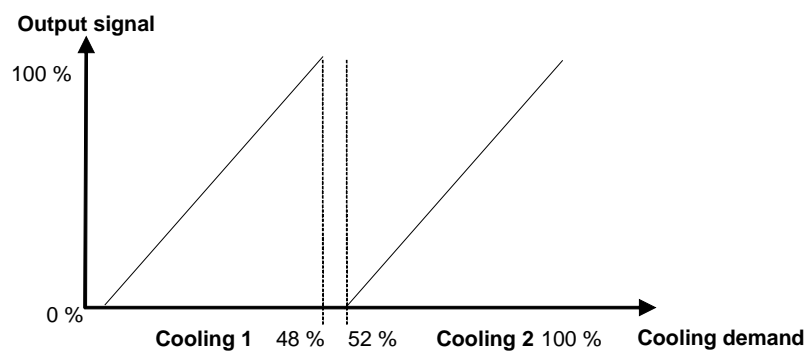

Chapter 9 Operating modes

Different operating modes

The Regio controllers have the following operating modes:

- 0 = Off
- 1 = Unoccupied
- 2 = Stand-by
- 3 = Occupied (FS)
- 4 = Bypass

Off

Operating mode Off means that the controller is not heating or cooling, and the fans are stopped. However, the temperature may not drop below the set minimum temperature (FS=8°C). If it does, the controller will start heating, and (if a fan is used) start the fan whether it has been manually stopped or not.

For room units with display the background lighting is not lit, and only OFF is shown in the display.

Unoccupied

Operating mode Unoccupied means that the room where the controller is placed is not used for an extended period of time, for example during holidays or long weekends. Both heating and cooling are disconnected and the fans are stopped within a temperature interval with configurable min/max temperatures (FS min=15°C, max=30°C).

For room units with display the background lighting is not lit, but the current room temperature (or setpoint depending on the configuration) is shown in the display. OFF is also shown in the display.

Stand-by

Operating mode Stand-by means that the room is in an energy save mode and is not used at the moment. This can be during nights, weekends, evenings etc. The controller is prepared to change operating mode to Occupied (comfort) if someone enters the room (presence). The room temperature is controlled around the applicable heating and cooling setpoints, with an extended temperature interval (FS=+/-3°C). For example, if the heating setpoint=22°C and the cooling setpoint=24°C, the controller will allow the temperature in the room to be between 19°C and 27°C. The setpoints can also be adjusted +/- 3°C via the setpoint knob or the display of the room unit.

For room units with display the background lighting is lit (dimmed). STANDBY and the current room temperature (or setpoint depending on the configuration) are shown in the display.

Shutdown

When the Occupancy button is held depressed for more than 5 seconds, the controller changes operating mode to "Shutdown" (Off/Unoccupied), regardless of the current operating mode. Via the display or Regio tool[®], you can configure which operating mode, Off or Unoccupied, should be activated on "Shutdown". The factory setting is that Unoccupied is activated.

If you press the Occupancy button for less than 5 seconds when the controller is in operating mode Shutdown or the preset operating mode, the controller changes to operating mode Bypass. If you press the button for less than 5 seconds when the controller is in Bypass, it changes operating mode to the Preset operating mode.

After a configurable time in Bypass (FS=2 hours), the controller returns to the preset operating mode.

For handling of the Occupancy button in combination with local time control and central control, see the sections Local time control and Central control below.

Occupancy detector

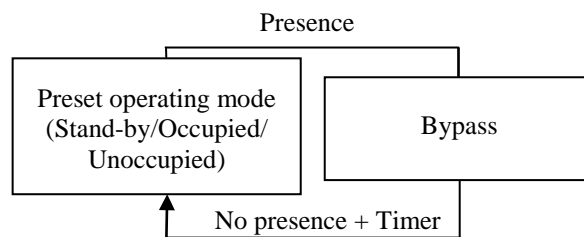

For local control of the operating mode between the preset operating mode and Bypass, an occupancy detector is connected.

When occupancy is indicated, the controller changes operating mode to Bypass. If you want to be able to enter the room temporarily without activating Bypass, for example to pick something up, you can configure a power-up delay. This means that Bypass is not activated until the power-up delay has expired. The Bypass delay can be set to a value between 0 and 60 minutes (FS=0 min).

In Bypass on presence, there is a switch-off timer, which means that if there is no occupancy indication during this time (FS=10 min), the controller will return to the preset operating mode.

Local time control

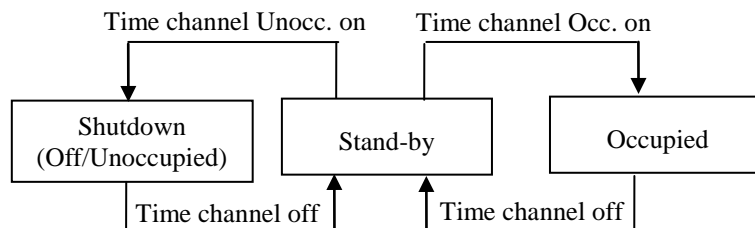

Maxi can be controlled using local time control. This means that there are two time channels, one time channel Occupied for changing between Stand-by and Occupied, and one time channel Unoccupied for changing between Stand-by and Shutdown. If both time channels are active at the same time, the time channel for Occupied will take precedence.

The Occupancy button Pressing the Occupancy button overrides the local time control. I. e. if the controller is in Occupied mode and you press the Occupancy button, Bypass will be activated for 2 hours. The controller will then return to Occupied. If you press the Occupancy button again when the controller is in Bypass mode, Stand-by will be activated even if time channel Occupied is on.

If you press the Occupancy button when the controller is in Bypass and time channel Unoccupied is on, the controller will change to Shutdown instead of Stand-by.

When the Occupancy button is held depressed for more than 5 seconds, the controller changes operating mode to Shutdown, regardless of the time control.

Central control

Central control of the operating mode is also possible. By changing the variable *RegioRemoteState*, you can control the operating mode centrally according to the following table (there is a variable list for central control in Part V of this manual):

RegioRemoteState	Description
0	Central operating mode Off
1	Central operating mode Unoccupied
2	Central operating mode Stand-by
3	Central operating mode Occupied
4	(Not used)
5 (FS)	No central control

Table 9. The variable *RegioRemoteState*

The occupancy button When using central control (i. e. *RegioRemoteState* \neq 5) and you press the Occupancy button, the controller will change to Bypass and stay in this mode for as long time as you have configured. If you press the Occupancy button again when the controller is in Bypass, the controller will change to Stand-by, regardless of what has been set in the central control (*RegioRemoteState*).

When the controller is in Bypass and the Bypass time has run out, the controller will change to the operating mode given by *RegioRemoteState*. If *RegioRemoteState* equals 5 it will change to the preset operating mode.

If the controller is in Stand-by and the central control is changed, the controller will change to this new operating mode.

Occupancy detector When central control is used and the occupancy detector is activated, the controller will go to Bypass for a configurable time, and thereafter return to the central operating mode.

Central command

Via central commands from a comprehensive system, for example EXO4, you can handle the controller in the same way as you handle it locally via the Occupancy button, i. e. you can change its operating mode to Off/Unoccupied (Shutdown) or Bypass.

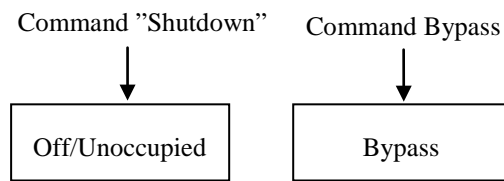

Central commands should be regarded as events and can be changed locally via the Occupancy button.

Chapter 10 Setpoint calculation

Basic setpoint

There are two basic setpoints, one basic heating setpoint and one basic cooling setpoint (FS basic heating setpoint=22°C, cooling=24°C). In RU-units with dipswitches for setting the basic setpoint (RU-units without display), the basic heating setpoint is set. The basic cooling setpoint is automatically changed at the same time. Therefore, the difference between the basic heating setpoint and the basic cooling setpoint is always the same.

Basic setpoint (°C)	SW1	SW2
20	OFF	OFF
22 (FS)	OFF	ON
24	ON	OFF
26	ON	ON

Table 10. Setting of basic heating setpoint with dipswitch SW1 and SW2

On RU-models with display, the basic setpoint is set in the display.

On all room units, you can also configure the setpoints via a central system or Regio tool[®]. When the model has dipswitches, the latest setpoint change will be valid.

Setpoint displacement

The setpoint value can be adjusted up and down from the basic setpoint value, via the setpoint knob or the display. How much the value can be adjusted can be configured in Regio tool[®] or in the parameter menu in the display (FS=+/-3°C).

In room units with display, you use the INCREASE button to increase the current setpoint in steps of 0.5°C to the max. limit, and the DECREASE button to decrease the current setpoint in steps of 0.5°C to the min. limit.

Calculation of the active setpoint

What setpoint value the controller should control according to depends on the operating mode, the control state and the current setpoint displacement.

Off

In operating mode Off or on open window the controller is a heating controller and controls according to the frost protection setpoint (FS=8°C), regardless of the setpoint displacement.

Unoccupied

In operating mode Unoccupied, it controls according to the heating setpoint (FS=15°C) if a control state with heating has been set and the room temperature is lower than this setpoint. If the room temperature is higher than the cooling setpoint (FS=30°C) and a control state with cooling has been set, the unit is a cooling controller and controls according to the cooling setpoint. The active setpoint changes in the middle of the neutral zone with a hysteresis of 0.1°C. A setpoint displacement is not active in this operating mode.

Stand-by

In operating mode Stand-by the controller controls according to the basic heating setpoint or the basic cooling setpoint plus/minus a settable neutral zone (FS=3°C). The setpoint can also be adjusted via the setpoint knob or display. This means that the factory setting for the heating setpoint is 19°C +/- 3°C (local displacement), and the factory setting for the cooling setpoint is 27°C +/- 3°C (local displacement). On heating demand the unit will control according to the heating setpoint, and on cooling demand it will control according to the cooling setpoint. The setpoint change takes place halfway between the setpoints with a hysteresis of 0.1°C.

Occupied/Bypass

In operating modes Occupied and Bypass the unit controls according to the basic heating setpoint or the basic cooling setpoint. The setpoint can also be adjusted via the setpoint knob or display. On heating demand it will control according to the heating setpoint, and on cooling demand it will control according to the cooling setpoint. The setpoint change takes place halfway between the setpoints with a hysteresis of 0.1°C.

Chapter 11 Actuators

Regio can be used with three types of actuators:

- Analogue 0...10 V actuators
- Thermal actuators
- 3-point actuators (Increase/Decrease actuators)

The actuator type is set via Regio tool[®].

Analogue actuators

The following output signals can be set for analogue actuators:

- 0...10 V (FS)
- 2...10 V
- 10...2 V
- 10...0 V

Thermal actuators

When thermal actuator control has been selected, this is controlled digitally with time proportional pulses via output UO.... By pulsing, the opening degree of the actuator (and its valve) is varied. The period time (in seconds) is the sum of the on and off output times on the output. The period time is FS=60s. The controller varies the on and off output times proportionally depending on the output signal demand to the actuator.

3-point actuators

For 3-point actuators (increase/decrease actuators), two digital outputs are used for controlling one actuator, one output to open the actuator and one to close it. You can configure the run time (in seconds) for the different actuators (FS=120 s). The program calculates the position of the actuator (0...100%) and sends an increase or decrease signal when the controller output signal deviates more than the set neutral zone (FS=2%) from the calculated position.

Actuator exercise

All actuators are exercised. An opening signal is sent to the actuator for as long time as the run time has been configured. Then a closing signal is sent for as long time and the exercise is finished. You can configure if the actuators should be exercised, which day you want the exercise to take place, or if it should take place every day. You can also configure at what time during the day the exercise should occur (FS=Every day at 3 pm).

Chapter 12 Fan control

In room units for fan control (RU-F-models) it is possible to control a fan at the following speeds: Off, Low speed, Medium speed, High speed, Auto. The fan speed in the Auto position depends on the controller output signal and the settings for each speed.

Manual control

The fan can be manually controlled to work at any speed. On RU-models with display, you press the fan button once and a fan symbol is lit for 10 seconds in the display. As long as the symbol is lit, you can change the fan speed with the INCREASE/DECREASE buttons. RU-models without display have a fan switch.



Figure 13. Fan button on room units with display



Figure 14. Fan switch on room units without display

The controller has the following positions:

- Auto** = Automatic control of the fan speed to maintain desired room temperature
- 0** = Fan off
- I** = Manual position with low speed
- II** = Manual position with medium speed
- III** = Manual position with high speed

Manual setting of speed I-III means that the speed of the fan in operating modes Stand-by, Occupied and Bypass is always the set speed. In the other operating modes, the fan is demand controlled.

Auto control

In auto mode, you can configure if the fan should be controlled by the heating output, the cooling output, or both the heating and cooling outputs. When the selected output exceeds the start value that has been set for each speed (FS speed 1=20%, speed 2=60%, speed 3=100%), the fan is activated. It stops when the controller output signal drops below the set value minus the set hysteresis (FS=5%).

When the fan speed changes, there is always a minimum delay (2-3 s) between the inactivation of the output for the current speed and the activation of the output for the new speed. Only one fan speed output is defined at a time.

Select button

For room units with a Select button it is also possible to set the maximum speed in the auto position: Auto 1, Auto 2 or Auto 3. Auto 1 means that the maximum speed is 1, Auto 2 that the maximum speed is 2 and so on.

Off/Unoccupied

In operating modes Off and Unoccupied, the fan is stopped, regardless of the position of the fan switch or the setting in the display, on condition that the temperature is within the set temperature limits. If the temperature is not within the set temperature limits, the fan will be started in the corresponding Auto position, regardless of the settings.

Chapter 13 Change-over function

Change-over is a function for installations with 2-pipe systems. It makes it possible to use the same pipe for both heating and cooling, depending on requirements during for example the summer (cooling output) and the winter (heating output).

Control states

To activate the change-over function, control mode Heating or cooling via the change-over function should be configured.

All controllers in the Regio series have an input for change-over. The input can be either of the type analogue Pt1000-sensor or a closing contact connected to a digital input (FS=Pt1000-input).

The Pt1000-sensor is mounted so that it senses the temperature on the feed wire to the battery. If the temperature drops below 18°C (FS), change-over is activated and the configured heating output is set to cooling. When the temperature exceeds 22°C (FS) the change-over function is deactivated and the heating output is set to heating.

When using a digital signal input (potential-free contact), closing the contact switches the change-over function and sets the heating output to cooling. On open contact, the change-over function sets the heating output to heating.

It is also possible to control change-over via a central command. See the variable list in Part V of this manual.

Chapter 14 Forced ventilation / Condensation detector / Frost protection

Forced ventilation

All controllers in the Regio series have a digital output for controlling a forcing damper to increase the airflow to the room. This output is always activated in operating mode Bypass.

When control state “Heating/Cooling with VAV-control and forced supply air function” is active, the cooling output is used to control the forcing damper. When forced ventilation is active, the cooling output is set to full cooling, regardless of what the controller output signal is.

Condensation detector

Special input CI

There is a special input (CI) on all Regio controllers. This input is intended for Regio’s condensation detector, KG-A/1, and functions internally as a digital input, i. e. condensation or no condensation.

When the condensation detector is activated, the cooling control is blocked and the controller is set in neutral position. When condensation ceases, the controller will start controlling from the neutral position.

Frost protection

Regio has built-in frost protection, which is activated when the controller is not in use. The frost protection prevents the temperature from dropping below 8°C. Return to normal fan speed and control occurs automatically when the room temperature exceeds 8°C.

Chapter 15 Indications

Indications on the RU-units

LED

All room units without display have a LED shaped like a thermometer on the front. A red indication is shown when heating control is functional and a blue indication is shown when cooling control is active. When there is something wrong with the controller, the LED flashes red and blue.



Figure 15. The LED

The occupancy button

On room units without display, the occupancy button has the following indications:

- Occupied: Fixed green indication
- Standby: Flashing green indication
- Bypass: Fixed green indication with a short flash
- Off and Unoccupied: No indication



Figure 16. The occupancy button

For RU-models with display, these indications are shown in the display, see the chapter *Display handling*.

Communication LED

When the frame of the room units has been removed, a LED is visible in the right edge of the controller. It lights up green when the controller is sending information.

Indications on the RCP-units

Adjacent to terminals 40-43 and 80, there are a number of LED:s which indicate status.



Figure 17. LED:s on RCP

Designation	Colour	Description
P/B (Power supply/Battery)	Green/Red	Power supply on/Battery error
Lan/Serv	Green/Yellow	For TCP/IP status indication
Rx	Green	Port 1, Receiving
Tx	Green	Port 1, Transmitting
RURX	Green	Port RU, Receiving

Table 11. The function of the LED:s

Chapter 16 Functions for RU-DOS

The Select button

RU-DOS is a flexible room unit. It has a special button, the Select button, and a number of special functions which are described below.



Figure 17. RU-DOS

Lighting control

When the RCP-controllers are connected to RU-DOS, they can be used for controlling lighting. A digital output is configured. The lighting can be controlled in different ways:

Manual control

The lighting can be controlled manually, either locally via the Select button or centrally via a comprehensive system or Regio tool[®].

Time control

Switch-on/switch-off times for each weekday can be configured locally in the controller. The times can be changed locally in the parameter menu in the display of RU-DOS or via Regio tool[®].

Presence control

If the lighting is presence controlled, it is lit on presence indication.

Time control and presence control

Time and presence control can be combined. The lighting is lit either when the local time channel is active or on presence indication.

Control of blinds

The controllers can also be used for controlling blinds. A digital output is configured. The blinds can be controlled locally via the Select button or centrally via a comprehensive system or Regio tool[®].

CO₂-transmitter

If you want it to monitor the current percentage of CO₂ in the room, a CO₂-transmitter can be connected to the controller. It is also possible to activate presence when the percentage of CO₂ rises above a set limit value (FS=800ppm) and deactivate presence when the percentage of CO₂ drops below a set limit value minus a hysteresis (FS=160ppm).

Humidity sensor

By connecting a humidity sensor, the current relative humidity (% RH) in the room can also be measured. The value is shown locally in the display or in a central system.

Outdoor temperature sensor

It is also possible to connect a sensor that measures the current outdoor temperature. The value is shown locally in the display or in a central system.

Chapter 17 Display handling

The room units RU-DO, RU-DFO and RU-DOS have a display instead of a setpoint knob.

INCR./DECR. button These models also have an Occupancy button, as well as an INCREASE button and a DECREASE button to increase and decrease the setpoint.

The Select button on RU-DOS allows you to make more advanced settings and see more indications in the display (see the section *The Select button* below).

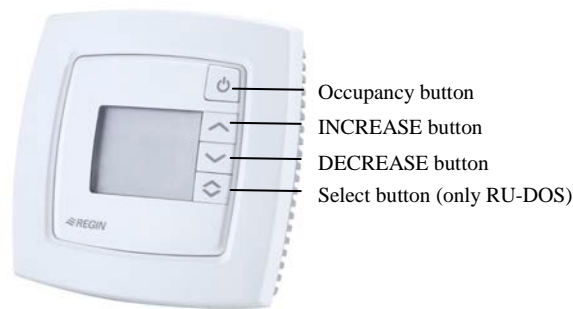

Figure 18. Buttons for display handling

Display indications

The display has the following indications (indications marked with an asterisk (*) are only available on RU-F-models):

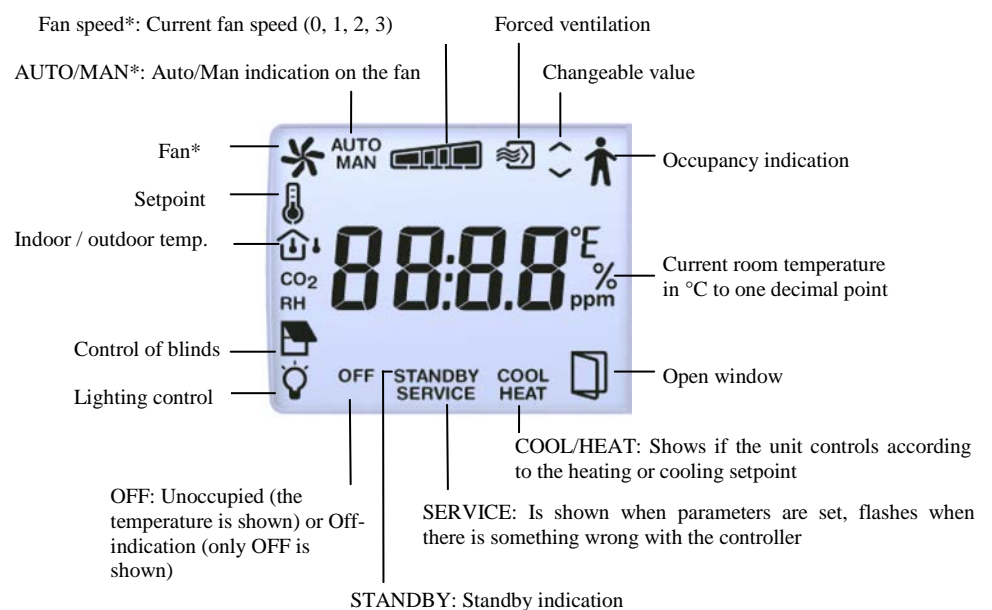

Figure 19. Indications in the display

The Select button

By pressing the Select button on RU-DOS, you move between the following indications:

- Fan speed. When this symbol is lit you change the fan speed with the INCREASE/DECREASE buttons.
- Current setpoint in °C to one decimal point and 0.5°C resolution
- Current outdoor temperature in °C to one decimal point and 0.1°C resolution
- CO₂: Current percentage of CO₂ 0...9999 ppm
- RH: Current humidity 0...100% RH
- Lighting control: The lighting can be turned on/off with the INCREASE/DECREASE buttons.
- Control of blinds: The blinds can be controlled with the INCREASE/DECREASE buttons. The output for opening the blinds is active as long as you are holding the INCREASE button depressed, and the output for closing the blinds is active as long as you are holding the DECREASE button depressed.

The parameter menu

In the RU-units with display it is possible to set different parameter values in a parameter menu. The parameter menu is accessed by simultaneously holding the INCREASE and DECREASE buttons depressed for about 5 seconds and then pressing the INCREASE button twice. The Service indication will be displayed.

First the display will show the parameter-number 1. Scroll between parameters by using the INCREASE and DECREASE buttons.

Press the Occupancy button to select the desired parameter. The parameter number will be replaced by the parameter value. The value can be changed using the INCREASE and DECREASE buttons. If a button is held depressed the value will start scrolling, first slowly and then with increasing speed in 3 - 4 steps with 2 - 3 seconds between steps.

Acknowledge/Regret

To acknowledge and store a set parameter value, press the Occupancy button again, the display then returns to showing the parameter number. To retrieve the original value, i.e. the value before change, press the INCREASE and DECREASE buttons at the same time. The original value is shown on the display.

Return

After a certain time, about 1 minute, or when the INCREASE and DECREASE buttons are pressed at the same time while in the menu, the display returns to the normal view. Exit is shown on the display after the last parameter. The parameter menu is exited by pressing the Occupancy button while in Exit. Pressing on INCREASE goes to the first parameter and pressing on DECREASE goes to the last parameter.

Parameters

The following parameters can be changed in the parameter menu (FS = Factory setting):

Parameter number	Description	FS
1	Basic heating setpoint	22°C
2	Basic cooling setpoint	24°C
3	Neutral zone at Stand-by, Heating sp=Basic sp heating-3, Cooling sp=Basic sp cooling+3	3°C
4	Heating setpoint at Unoccupied	15°C
5	Cooling setpoint at Unoccupied	30°C

6	Frost protection setpoint	8°C
7	P-band for room controller	10°C
8	I-time (s) for room controller	300 s
9	With a lower temperature on the analogue Change-over input, the cooling function is selected	18
10	With a higher temperature on the analogue Change-over input, the heating function is selected	22
11	Control states: 0=Heat, 1=Heat/Heat, 2=Heat or cooling via Change-over, 3=Heat/Cooling, 4=Heat/Cooling with VAV-control and forced supply air, 5=Heat/Cooling with VAV control, 6=Cooling, 7=Cooling/Cooling	3
12	Time in Bypass mode	120 min
13	Disconnect timer with occupancy/unoccupancy	10 min
14	Switch on delay for occupancy	0 min
15	State connected sensor on AI1: 0= None, 1=Room sensor, 2=Change-over, 3=Condensation detector, 4=Outdoor sensor, 5=CO ₂ , 6=Humidity sensor	1
16	State connected sensor on AI2: The same options as for AI1 (see above).	2
17	State connected sensor on DI1: 0=None, 1=Window contact, 2= Condensation detector, 3=Presence, 4=Change-over	3
18	State connected sensor on DI2: The same options as for DI1.	1
19	State connected sensor on DI3: The same options as for DI1.	2
20	State function of signal on AO1: 0=None, 1=Heating actuator, 2=Cooling actuator	1
21	State function of signal on AO2: 0=None, 1=Heating actuator, 2=Cooling actuator	2
22	State function of signal on DO1: 0=Ingen, 1=Fan speed 1, 2=Fan speed 2, 3=Fan speed 3, 4=Forced ventilation, 5=Thermal actuator heating, 6=Thermal actuator cooling, 7=Heating actuator increase, 8=Heating actuator decrease, 9=Cooling actuator increase, 10=Cooling actuator decrease, 11=Lighting, 12=Control of blinds open, 13=Control of blinds close	RCP100=4 RCP200=4 RCP100-F=1 RCP200-F=1
23	State function of signal on DO2: The same options as for DO1.	RCP100=0 RCP200=0 RCP100-F=2 RCP200-F=2
24	State function of signal on DO3: The same options as for DO1.	RCP100=5 RCP200=0 RCP100-F=3 RCP200-F=3
25	State function of signal on DO4: The same options as for DO1.	RCP100=6 RCP200=0 RCP100-F=4 RCP200-F=4
26	State function of signal on DO5: The same options as for DO1.	RCP100=0 RCP200=0 RCP100-F=0 RCP200-F=0
27	State function of signal on DO6: The same options as for DO1.	RCP100=0 RCP200=0 RCP100-F=5 RCP200-F=0
28	State function of signal on DO7: The same options as for DO1.	RCP100=0 RCP200=0 RCP100-F=6 RCP200-F=0

29	State type of heating actuator: 0=0...10V, 1=2...10V, 2=10...2V, 3=10...0V	0
30	State type of cooling actuator: 0=0...10V, 1=2...10V, 2=10...2V, 3=10...0V	0
31	Period time for heating actuator with thermal actuator	60 s
32	Period time for cooling actuator with thermal actuator	60 s
33	Run time for heating actuator with increase/decrease actuator	120 s
34	Run time for cooling actuator with increase/decrease actuator	120 s
35	Neutral zone for increase/decrease actuator	2%
36	Day for exercise of heating actuator 0=never, 1-7=Mon-Sun, 8=every day	8
37	Day for exercise of cooling actuator 0=never, 1-7=Mon-Sun, 8=every day	8
38	Hour for exercise of heating actuator	15
39	Hour for exercise of cooling actuator	15
40	Minute for exercise of heating actuator	0
41	Minute for exercise of cooling actuator	0
42	Select if setpoint or actual value is to be shown on display, 0=Actual, 1=Heating setpoint, 2=Cooling setpoint, 3=Average value of heating and cooling setpoint, 4=Only setpoint displacement	0
43	Highest permitted setpoint offset upwards	3°C
44	Highest permitted setpoint offset downwards	3°C
45	Preset operating mode: 0=Off, 1=Unoccupied, 2=Stand-by, 3=Occupied. Forced ventilation is not set in Occupied mode.	3
46	State operating mode by depressing Occupancy button for 5 sec: 0=Off, 1=Unoccupied, 2=Stand-by, 3=Occupied. Forced ventilation is not set in Occupied mode.	1
47	Select operating mode for central control: 0=Off, 1=Unoccupied, 2=Stand-by, 3=Occupied, 5=No central control	5
48	Min flow at cooling output when control state Heat/cool with VAV-control is selected	20
49	Max flow at cooling output when control state Heat/cool with VAV-control is selected and heating is applied	0
50	Configuration of fan control: 0=No control, 1=The fan is controlled by heating requirement, 2=The fan is controlled by cooling requirement, 3=The fan is controlled by heating and cooling requirement	3
51	Start signal in % for fan speed 1 on heating or cooling control	20
52	Start signal in % for fan speed 2	60
53	Start signal in % for fan speed 3	100
54	Hysteresis for start/stop of fans	5
55	State number of speeds for fan	3
56	Temperature compensation on AII	0°C
57	Temperature compensation on UII	0°C
58	Temperature compensation for internal room sensor	0°C
59	Filter factor for analogue temperature inputs	0.2
60	State NO/NC digital input 1 0=NO (Normally open), 1=NC (Normally closed)	0
61	State NO/NC digital input 2 0=NO (Normally open), 1=NC (Normally closed)	1
62	State NO/NC digital input 3 0=NO (Normally open), 1=NC (Normally closed)	0
63	Manual/Auto heating output signal: 0=Off, 1=Manual, 2=Auto	2
64	Manual/Auto cooling output signal: 0=Off, 1=Manual, 2=Auto	2
65	Manual/Auto forced ventilation: 0=Off, 1=On, 2=Auto. Can e.g. be activated from a central system for e.g. night cooling	2
66	Manual/Auto control of change-over mode: 0=Heating control, 1=Cooling control, 2=Automatic change-over depending on analogue temperature sensor or digital input	2

67	Heating output signal in manual mode	0
68	Cooling output signal in manual mode	0
69	Controller Modbus address	254
70	Parity bit Modbus communication: 0=No parity, 1=Odd parity, 2=Even parity	2
72	Modbus communication speed: 0=9600, 1=4800, 2=2400 etc. 15=19200	0
73	Activate Modbus as default in Regio Maxi: 0=Off, 1=On	0
85	Alarm hysteresis	0.2
86	Alarm limit high room temperature	40
87	Alarm limit low room temperature	15
88	Max room temperature deviation	20
89	Alarm limit high condensation	80
90	Hysteresis condensation alarm	2
91	Activate the logging function for EXO4	1
92	Activate alarms and events for EXO4 (0=Not active, 1=Only alarms, 2=Only events, 3=Both alarms and events active)	3
93	Enable automatic switch between summer time and normal time	1
94	State function for lighting control 0=Manual control, 1=Time control, 2=Presence control, 3=Time and presence control	0
95	Manual control of the lighting	0
96	Activate presence if the percentage of CO ₂ is high	0
97	Activate presence if CO ₂ is higher	800
98	Deactivate presence if CO ₂ is below the limit value minus this hysteresis	160
99	Filter factor for the condensation input	0.2
100	Filter factor for CO ₂ -input	0.2
101	Filter factor for RH-input	0.2
102	Condensation at 0V	0
103	Condensation at 10V	100
104	CO ₂ at 0V	0
105	CO ₂ at 10V	1000
106	RH at 0V	0
107	RH at 10V	100
108	Command for taking the blinds in	0
109	Command for taking the blinds out	0
110	Run time for controlling the blinds in/out	240
111	Activate condensation detector on the CI-input 0=Not active, 2=Condensation detector active	2
130	The controller's current time (second)	
131	The controller's current time (minute)	
132	The controller's current time (hour)	
133	The controller's current time (weekday)	
134	The controller's current time (week number)	
135	The controller's current time (date)	
136	The controller's current time (month)	
137	The controller's current time (year)	
138	Start time Monday Occupied	0
139	Start time Tuesday	0
140	Start time Wednesday	0
141	Start time Thursday	0
142	Start time Friday	0
143	Start time Saturday	0
144	Start time Sunday	0
145	Start time holidays	0
146	Stop time Monday	0
147	Stop time Tuesday	0

148	Stop time Wednesday	0
149	Stop time Thursday	0
150	Stop time Friday	0
151	Stop time Saturday	0
152	Stop time Sunday	0
153	Stop time holidays	0
154	Start time 2 Monday Occupied	0
155	Start time Tuesday	0
156	Start time Wednesday	0
157	Start time Thursday	0
158	Start time Friday	0
159	Start time Saturday	0
160	Start time Sunday	0
161	Start time holidays	0
162	Stop time Monday	0
163	Stop time Tuesday	0
164	Stop time Wednesday	0
165	Stop time Thursday	0
166	Stop time Friday	0
167	Stop time Saturday	0
168	Stop time Sunday	0
169	Stop time holidays	0
170	Start time 1 Monday Unoccupied	0
171	Start time Tuesday	0
172	Start time Wednesday	0
173	Start time Thursday	0
174	Start time Friday	0
175	Start time Saturday	0
176	Start time Sunday	0
177	Start time holidays	0
178	Stop time 1 Monday Unoccupied	0
179	Stop time Tuesday	0
180	Stop time Wednesday	0
181	Stop time Thursday	0
182	Stop time Friday	0
183	Stop time Saturday	0
184	Stop time Sunday	0
185	Stop time holidays	0
186	Start time 2 Monday Unoccupied	0
187	Start time Tuesday	0
188	Start time Wednesday	0
189	Start time Thursday	0
190	Start time Friday	0
191	Start time Saturday	0
192	Start time Sunday	0
193	Start time holidays	0
194	Stop time 2 Monday Unoccupied	0
195	Stop time Tuesday	0
196	Stop time Wednesday	0
197	Stop time Thursday	0
198	Stop time Friday	0
199	Stop time Saturday	0
200	Stop time Sunday	0
201	Stop time holidays	0
202	Start time 1 Monday Lighting	0

203	Start time Tuesday	0
204	Start time Wednesday	0
205	Start time Thursday	0
206	Start time Friday	0
207	Start time Saturday	0
208	Start time Sunday	0
209	Start time holidays	0
210	Stop time 1 Monday Lighting	0
211	Stop time Tuesday	0
212	Stop time Wednesday	0
213	Stop time Thursday	0
214	Stop time Friday	0
215	Stop time Saturday	0
216	Stop time Sunday	0
217	Stop time holidays	0
218	Start time 2 Monday Lighting	0
219	Start time Tuesday	0
220	Start time Wednesday	0
221	Start time Thursday	0
222	Start time Friday	0
223	Start time Saturday	0
224	Start time Sunday	0
225	Start time holidays	0
226	Stop time 2 Monday Lighting	0
227	Stop time Tuesday	0
228	Stop time Wednesday	0
229	Stop time Thursday	0
230	Stop time Friday	0
231	Stop time Saturday	0
232	Stop time Sunday	0
233	Stop time holidays	0
234	Start date holiday 1	1.01
235	Start date holiday 2	1.01
236	Start date holiday 3	1.01
237	Start date holiday 4	1.01
238	Start date holiday 5	1.01
239	Start date holiday 6	1.01
240	Start date holiday 7	1.01
241	Start date holiday 8	1.01
242	Start date holiday 9	1.01
243	Start date holiday 10	1.01
244	Stop date holiday 1	1.01
245	Stop date holiday 2	1.01
246	Stop date holiday 3	1.01
247	Stop date holiday 4	1.01
248	Stop date holiday 5	1.01
249	Stop date holiday 6	1.01
250	Stop date holiday 7	1.01
251	Stop date holiday 8	1.01
252	Stop date holiday 9	1.01
253	Stop date holiday 10	1.01

Table 12. Parameter list

Part IV **Maintenance and service**

Table of contents

Part IV Maintenance and service

<i>Chapter 18</i>	Maintenance and service	76
	Changing the battery	76
	Updating EXOreal	76
	Resetting the application memory	77
	Removing the cover	77

Chapter 18 Maintenance and service

Changing the battery

Note! This procedure requires knowledge of proper ESD protection; i.e. an earthed wristband must be used. How to lift off the cover is described in the section *Removing the cover* below.

When the battery LED on the RCP is lit, the battery for backup of program memory has become too weak. Replace the battery as described below. A backup capacitor saves the memory for at least 10 minutes after the power supply has been removed. Thus, if battery replacement takes less than 10 minutes there will be no need to reload the program.

The replacement battery must be of the type CR2032.

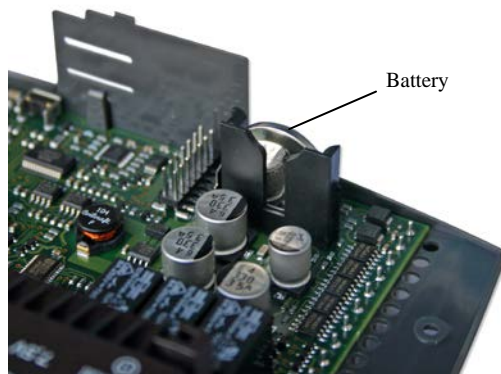

Figure 20. The position of the battery

Grip the battery firmly with your fingers and lift it upwards until it rises from its holder. Press the new battery firmly down into place. Note that to preserve correct polarity, the battery can only be inserted the “right way round”.

Updating EXOreal

Note! This procedure may only be carried out by qualified resellers and requires advanced knowledge.

The operation system is updated from the RS485 port. Use EXOdesigner.

Part V **Signals**

Table of contents

Part V **Signals**

<i>Chapter 19</i> Signal types	80
<i>Chapter 20</i> Signals	82
Input Status Register	82
Coil Status Register	83
Input Register	84
Holding Register	85
LonWorks network variables	94

Chapter 19 Signal types

EXOL type

The EXOL type of the signals:

R = Real (-3.3E38 - 3.3E38)

I = Integer (-32768 - 32767)

X = Index (0 - 255)

L = Logic (0/1)

Modbus type

The Modbus type of the signals (type in the list below):

1 = Coil Status Register (Modbus function = 1, 5 and 15)

2 = Input Status Register (Modbus function = 2)

3 = Holding Register (Modbus function = 3, 6 and 16)

4 = Input Register (Modbus function = 4)

Supported Modbus functions:

1 = Read Coils

2 = Read Discrete Input

3 = Read Holding Register

4 = Read Input Register

5 = Write Single Coil

6 = Write Single Register

15 = Write Multiple Coils

16 = Write Multiple Registers

Max 47 register

Max 47 register can be read in one message.

Communication limits

The modbus master must wait for a minimum of 3.5 character times (4ms at 9600 bps) between two messages. When the modbus master communicate with more than one controller on the same communication line (RS485), the modbus master must wait for a minimum of 14 character times (16ms at 9600bps) between the answer and the first question for the next controller.

In the controller there is a limit of 10 fast communications in every half minute, the other communications will have a delayed answer of approximately 1 second.

Scale factor Modbus

All real signals have scale factor 10 except the time settings signals that have scale factor 100 for modbus communication. Integer, Index and Logic has always scale factor 1.

EXOline/Modbus

The factory setting for the Maxi controller is Modbus communication. If you try to communicate EXOline, the controller will automatically change to EXOline communication after the first communication attempt. 10 seconds after the last EXOline communication, the controller will return to Modbus communication. You can also set the controller to only communicate EXOline, via Regio tool[®] or a parameter in the display.

Modbus wiring etc.

A protocol such as Modbus consists of several layers (OSI-model). The bottom layer is always the physical layer, number of wires and signal levels. the next layer describes the communication digits (number of data bits, stop-bits, parity etc). Then come the layers describing the Modbus specific functions (number of digits per message, the meaning of different messages etc).

For Modbus, the bottom layer can be RS485, RS422 or RS232.

RS485 contra RS422

RS485 and RS422 are the electric part of the protocol, i. e. the physical layer. RS485 has two connections, A and B. Often there is also a protective earth (N on EXOmodules). RS485 units are always connected A → A and B → B. RS485 is so called half duplex communication: Communication can only go in one direction at a time; i. e. the master will first send an enquiry and will thereafter listen for the reply. A and B are used for both transmission and reception.

RS422 is a full duplex communication which means you need 4 wires, 2 for transmit (Tx+ and Tx-) and 2 for receive (Rx+ and Rx-). Tx is used to transmit and Rx to receive which means that Tx in one unit must be connected to Rx in the other and vice versa. As for signal levels etc. RS422 and RS485 are identical.

To interconnect RS485 and RS422: On the RS422 unit connect Tx+ with Rx+ and Tx- with Rx-. We have now changed a 4-wire system to a 2-wire system and can connect them to A and B on the RS485 unit. Which goes where is something you most often need to find out by trial and error. Incorrect polarity will just give nonfunction but cannot harm either unit.

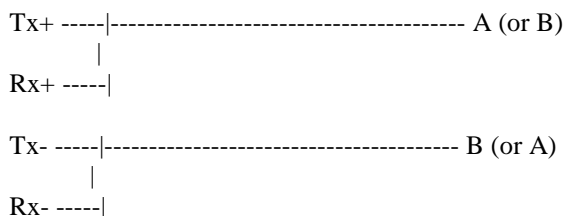

Bitrate, two stop bits, parity is the next layer.

These settings must correspond to the settings in the master unit. Find out how the master is set and then give the Controller the same settings.

Parity can be set to odd, even or none. If none is chosen two stopbits will automatically be used. If odd or even is chosen only one stop-bit is used otherwise there will be too many bits altogether: 1 start-bit, 8 data-bits, 1 parity-bit and 1 stop-bit give a total of 11 bits which is maximum.

LonWorks

Models with LON communication have a communication port for LonWorks. Connection to the network is established using the programming tool LonMaker. The xif-file is available for download from Regin's homepage. Network variables for LON can be found at the end of chapter 20.

Chapter 20 Signals

Input Status Register

Signal name	Type	Modbus address	Default value	Description
RCPActual.RegioDigIn(0)	L,2	1		Not used
RCPActual.RegioDigIn1	L,2	2		Value of digital input 1.
RCPActual.RegioDigIn2	L,2	3		Value of digital input 2.
RCPActual.RegioDigIn3	L,2	4		Value of digital input 3.
RCPActual.RegioDigOut(0)	L,2	5		Not used
RCPActual.RegioDigOut1	L,2	6		Value of digital output 1.
RCPActual.RegioDigOut2	L,2	7		Value of digital output 2.
RCPActual.RegioDigOut3	L,2	8		Value of digital output 3.
RCPActual.RegioDigOut4	L,2	9		Value of digital output 4.
RCPActual.RegioDigOut5	L,2	10		Value of digital output 5.
RCPActual.RegioDigOut6	L,2	11		Value of digital output 6.
RCPActual.RegioDigOut7	L,2	12		Value of digital output 7.
RCPActual.RegioDIOpenWindow	L,2	13		Indicate open window
RCPActual.RegioDICondensationAlarm	L,2	14		Indicate condensation alarm from digital input
RCPActual.RegioDIPresences	L,2	15		Indicate presence from digital input
RCPActual.RegioDIChangeOver	L,2	16		Indicate change over from digital input
RCPActual.RegioFanSpeed1	L,2	17		Indicate fan speed 1
RCPActual.RegioFanSpeed2	L,2	18		Indicate fan speed 2
RCPActual.RegioFanSpeed3	L,2	19		Indicate fan speed 3
RCPActual.RegioForcedventilation	L,2	20		Indicate forced ventilation
RCPActual.RegioCVHeatPulsProp	L,2	21		Indicate puls prop heating
RCPActual.RegioCVCoolPulsProp	L,2	22		Indicate puls prop cooling
RCPActual.RegioCVHeatInc	L,2	23		Indicate increase heating
RCPActual.RegioCVHeatDec	L,2	24		Indicate decrease heating
RCPActual.RegioCVCoolInc	L,2	25		Indicate increase cooling
RCPActual.RegioCVCoolDec	L,2	26		Indicate decrease cooling
RCPActual.RegioAIChangeOverState	L,2	27		Indicate change over state from analog input
RCPActual.RegioChangeOverState	L,2	28		Indicate change over state from both digital and analog input
RCPActual.RegioRoomTempSensorAlarm	L,2	29		Indicate sensor alarm on room sensor

RCPInternal.RegioNotUsedL	L,2	30		Not used
RCPInternal.RegioNotUsedL	L,2	31		Not used
RCPInternal.RegioNotUsedL	L,2	32		Not used
RCPInternal.RegioNotUsedL	L,2	33		Not used
RCPInternal.RegioNotUsedL	L,2	34		Not used
RCPInternal.RegioNotUsedL	L,2	35		Not used
RCPInternal.RegioNotUsedL	L,2	36		Not used
RCPActual.RegioCIn	L,2	37		Value of condensation input.
RCPActual.RegioLighting	L,2	38		Indicate lightning is on
RCPActual.RegioSumAlarm	L,2	39		Indicate sum alarm
RCPActual.RegioJalusi	L,2	40		Indicate jalusi is out
RCPActual.RegioCO2Presence	L,2	41		Indicate presence from CO ₂ sensor
RCPActual.RegioTGOccupied	L,2	42		Is set if timechannel Occupied is active
RCPActual.RegioTGUnOccupied	L,2	43		Is set if timechannel Unoccupied is active
RCPActual.RegioTGLighting	L,2	44		Is set if timechannel lightning is active
RCPActual.RegioAlaPt(1)	L,2	45		Indicate presence
RCPActual.RegioAlaPt(2)	L,2	46		Indicate Open window
RCPActual.RegioAlaPt(3)	L,2	47		Condensation alarm
RCPActual.RegioAlaPt(4)	L,2	48		Room temp high
RCPActual.RegioAlaPt(5)	L,2	49		Room temp low
RCPActual.RegioAlaPt(6)	L,2	50		Room temp deviation
RCPActual.RegioAlaPt(7)	L,2	51		Room controller in manual mode
RCPActual.RegioAlaPt(8)	L,2	52		Sensor alarm

Coil Status Register

Signal name	Type	Modbus address	Default value	Description
RCPSettings.RegioBypass	L,1	1	0	Force the unit in Bypass mode. Is automatically returned after Bypass time (default=120 min)
RCPSettings.RegioShutDown	L,1	2	0	Force the unit in ShutDown state
RCPInternal.RegioNotUsedL	L,1	3	0	Not used
RCPSettings.RegioDiNC(0)	L,1	4	0	Not used
RCPSettings.RegioDi1NC	L,1	5	0	Normally open (NO) or normally closed (NC) on digital input 1. 0=NO, 1=NC.
RCPSettings.RegioDi2NC	L,1	6	1	Normally open (NO) or normally closed (NC) on digital input 2. 0=NO, 1=NC.
RCPSettings.RegioDi3NC	L,1	7	0	Normally open (NO) or normally closed (NC) on digital input 3. 0=NO, 1=NC.
RCPInternal.RegioNotUsedL	L,1	8	0	Not used
RCPInternal.RegioNotUsedL	L,1	9	0	Not used
RCPInternal.RegioNotUsedL	L,1	10	0	Not used

RCPSettings.RegioLogActive	L,1	11	1	Activate logging function for EXO4
RCPSettings.RegioAutoSummerTime	L,1	12	1	Enable automatic switch between summer time and normal time. 0=Off, 1=On
RCPSettings.RegioLightManual	L,1	13	0	Control the light in manual mode.
RCPSettings.RegioCO2Function	L,1	14	0	Activate presence on CO ₂ sensor.
RCPSettings.RegioJalusiInCmd	L,1	15	0	Command jalusi in.
RCPSettings.RegioJalusiOutCmd	L,1	16	0	Command jalusi out
RCPSettings.RegioModbusComm	L,1	17	1	Activate modbus communication

Input Register

Signal name	Type	Modbus address	Default value	Description
RCPActual.RegioSoftware	X,4	1		Type of Regio software: 0 = RCP 1 = RC
RCPActual.RegioVerMajor	X,4	2		Major version
RCPActual.RegioVerMinor	X,4	3		Minor version
RCPActual.RegioVerBranch	X,4	4		Branch version
RCPActual.RegioRevision	X,4	5		Revision
RCPInternal.RegioNotUsedX	X,4	6		Not used
RCPActual.RegioUnitState	X,4	7		Indicate current unit state: 0 = Off 1 = Unoccupied 2 = Stand-by 3 = Occupied 4 = ByPass
RCPActual.RegioControllerState	X,4	8		Indicate current controller state: 0 = Off 1 = Heating 2 = Cooling
RCPActual.RegioFanSpeed	X,4	9		Indicate current fan speed: 0 = Off 1 = Fan speed 1 is on 2 = Fan speed 2 is on 3 = Fan speed 3 is on
RCPInternal.RegioNotUsedX	X,4	10		Not used
RCPActual.RegioRoomTemp	R,4	11		Room temperature
RCPActual.RegioRoomTempExt	R,4	12		Room temperature from external sensor
RCPActual.RegioRoomTempInt	R,4	13		Room temperature from internal sensor
RCPActual.RegioAIChangeOver	R,4	14		Change over temperature
RCPActual.RegioAnaIn1	R,4	15		Value of analog input 1
RCPActual.RegioAnaIn2	R,4	16		Value of analog input 2
RCPActual.RegioAnaOut1	R,4	17		Value of analog output 1
RCPActual.RegioAnaOut2	R,4	18		Value of analog output 2

RCPActual.RegioSetPAdjustment	R,4	19		Setpoint adjustment from internal device
RCPActual.RegioPIDSetP	R,4	20		The controller setpoint
RCPActual.RegioPIDOutput	R,4	21		The controller output (0-100%)
RCPActual.RegioHeatOutput	R,4	22		Heat output (0-100%)
RCPActual.RegioCoolOutput	R,4	23		Cool output (0-100%)
RCPInternal.RegioNotUsedX	X,4	24		Not used
RCPInternal.RegioNotUsedX	X,4	25		Not used
RCPInternal.RegioNotUsedX	X,4	26		Not used
RCPInternal.RegioNotUsedX	X,4	27		Not used
RCPInternal.RegioNotUsedX	X,4	28		Not used
RCPInternal.RegioNotUsedX	X,4	29		Not used
RCPActual.RegioOutDoorTemp	R,4	30		Outdoor temperature
RCPActual.RegioCondensation	R,4	31		Condensation input value (%)
RCPActual.RegioRoomCO2	R,4	32		CO ₂ input value (ppm)
RCPActual.RegioRoomRH	R,4	33		Room humidity (RH)
RCPActual.RegioByPassRunMin	I,4	34		Time left in ByPass mode (min)
Alarms.AlaModStat	X,4	35		Worst alarm status in controller
AlaData.AlaPt1_Status	X,4	36		Presence alarm status: 0 = Not used 1 = Normal 2 = Blocked 3 = Acknowledge 4 = Not used 5 = Cancelled 6 = Not used 7 = Alarm
AlaData.AlaPt2_Status	X,4	37		Open window alarm status
AlaData.AlaPt3_Status	X,4	38		Condensation alarm status
AlaData.AlaPt4_Status	X,4	39		Room temp high alarm status
AlaData.AlaPt5_Status	X,4	40		Room temp low alarm status
AlaData.AlaPt6_Status	X,4	41		Room temp deviation alarm status
AlaData.AlaPt7_Status	X,4	42		Room controller in manual mode alarm status
AlaData.AlaPt8_Status	X,4	43		Sensor alarm status

Holding Register

Signal name	Type	Modbus address	Default value	Description
RCPInternal.RegioNotUsedX	X,3	1	-	Not used
RCPInternal.RegioNotUsedX	X,3	2	-	Not used
RCPSettings.RegioHeatOutputSelect	X,3	3	2	Manual/Auto heat output
RCPSettings.RegioCoolOutputSelect	X,3	4	2	Manual/Auto cool output

RCPSettings.RegioFanSelect	X,3	5	4	Select fan mode: 0 = Off 1 = Manual speed 1 2 = Manual speed 2 3 = Manual speed 3 4 = Auto (5 = Auto 2) (only room unit with select (6 = Auto 1) button)
RC_Setp_X.RegioFanControlMode	X,3	6	3	Select fan control: 0 = No control 1 = The fan is controlled on heating demand 2 = The fan is controlled on cooling demand 3 = The fan is controlled by both heating and cooling demand
RCPSettings.RegioFanSpeed1Start	X,3	7	20	Controller output signal in % for fan speed 1 on heating or cooling control
RCPSettings.RegioFanSpeed2Start	X,3	8	60	Controller output signal in % for fan speed 2 on heating or cooling control
RCPSettings.RegioFanSpeed3Start	X,3	9	100	Controller output signal in % for fan speed 3 on heating or cooling control
RCPSettings.RegioFanSpeedHyst	X,3	10	5	Controller output hysteresis start/stop fan speed.
RCPSettings.RegioFanSpeedMax	X,3	11	3	Number of fan speeds (1-3)
RCPSettings.RegioForcedVentSelect	X,3	12	2	Manuell/Auto control of forced ventilation (0=Off, 1=On, 2=Auto)
RCPSettings.RegioChangeOverSelect	X,3	13	2	Manuell/Auto control of change-over (0=Heating, 1=Cooling, 2=Auto)
RCPSettings.RegioRemoteState	X,3	14	5	Is used for remote control unit state: 0 = Off 1 = Unoccupied 2 = Stand-by 3 = Occupied 5 = No remote control
RCPSettings.RegioUnitReturnState	X,3	15	3	Preset operating mode: 1= Unoccupied 2 = Stand-by 3 = Occupied
RCPSettings.RegioUnitShutDownState	X,3	16	1	Shutdown mode: 0 = Off 1 = Unoccupied
RCPSettings.RegioBtnOnOffTime	X,3	17	5	Time (in sec) that the Occupancy button must be held depressed before Shutdown mode.
RCPSettings.RegioControllerMode	X,3	18	3	Control states: 0 = Heating 1 = Heating/Heating 2 = Heating or cooling via the change-over function 3 = Heating/Cooling 4 = Heating/Cooling with VAV-control and forced supply air function 5 = Heating/Cooling with VAV-control 6 = Cooling 7 = Cooling / Cooling

RCPSettings.RegioCVHeatType	X,3	19	0	Actuator type heating: 0 = 0...10 V 1 = 2...10 V 2 = 10...2 V 3 = 10...0 V
RCPSettings.RegioCVCoolType	X,3	20	0	Actuator type cooling
RCPInternal.RegioNotUsedX	X,3	21	-	Not used
RCPInternal.RegioNotUsedX	X,3	22	-	Not used
RCPSettings.RegioAi(0)	X,3	23	-	Not used
RCPSettings.RegioAi1	X,3	24	0	Connected signal on AI1: 0 = Not used 1 = Room temperature 2 = Change-over temperature 3 = Outdoor temperature 4 = Condensation 5 = CO ₂ in room 6 = RH in room
RCPSettings.RegioAi2	X,3	25	2	Connected signal on AI2
RCPSettings.RegioDi(0)	X,3	26	-	Not used
RCPSettings.RegioDi1	X,3	27	3	Connected signal on DI1: 0 = Not used 1 = Open window 2 = Condensation alarm 3 = Presence 4 = Change-over
RCPSettings.RegioDi2	X,3	28	2	Connected signal on DI2
RCPSettings.RegioDi3	X,3	29	0	Connected signal on DI3
RCPSettings.RegioCi	X,3	30	2	Connected signal on CI
RCPSettings.RegioAo(0)	X,3	31	-	Not used
RCPSettings.RegioAo1	X,3	32	1	Connected signal on AO1: 0 = Not used 1 = Control valve heating 2 = Control valve cooling
RCPSettings.RegioAo2	X,3	33	2	Connected signal on AO2
RCPSettings.RegioDo(0)	X,3	34	-	Not used
RCPSettings.RegioDo1	X,3	35	1	Connected signal on DO1: 0 = Not used 1 = Fan speed 1 2 = Fan speed 2 3 = Fan speed 3 4 = Forced ventilation 5 = Control valve heating pulse prop. 6 = Control valve cooling pulse prop. 7 = Control valve heating increase 8 = Control valve heating decrease 9 = Control valve cooling increase 10 = Control valve cooling decrease 11 = Lighting 12 = Jalusi In 13 = Jalusi Out 14 = Sum alarm 15 = Sum alarm A 16 = Sum alarm B
RCPSettings.RegioDo2	X,3	36	2	Connected signal on DO2
RCPSettings.RegioDo3	X,3	37	3	Connected signal on DO3

RCPSettings.RegioDo4	X,3	38	4	Connected signal on DO4
RCPSettings.RegioDo5	X,3	39	0	Connected signal on DO5
RCPSettings.RegioDo6	X,3	40	5	Connected signal on DO6
RCPSettings.RegioDo7	X,3	41	6	Connected signal on DO7
RCPInternal.RegioNotUsedX	X,3	42	-	Not used
RCPInternal.RegioNotUsedX	X,3	43	-	Not used
RCPSettings.RegioModbusSlaveAddr	X,3	44		Modbus slave address
RCPSettings.RegioModbusParity	X,3	45	2	Modbus parity bit: 0 = No parity bit 1 = Odd parity bit 2 = Even parity bit
RCPInternal.RegioNotUsedX	X,3	46	-	Not used
RCPInternal.RegioNotUsedX	X,3	47	-	Not used
RCPSettings.RegioDispBacklightLO	X,3	48	20	Display lighting low (0..255)
RCPSettings.RegioDispBacklightHi	X,3	49	100	Display lighting high (0...255)
RCPSettings.RegioDispContrast	X,3	50	15	Contrast (0...15)
RCPSettings.RegioDisplayViewMode	X,3	51	0	Select viewmode for the display: 0 = Room temp 1 = Heat setpoint 2 = Cool setpoint 3 = Average cool/heat setpoint 4 = Only setpoint offset
RCPInternal.RegioNotUsedX	X,3	52	-	Not used
RCPInternal.RegioNotUsedX	X,3	53	-	Not used
RCPInternal.RegioNotUsedX	X,3	54	-	Not used
RCPInternal.RegioNotUsedX	X,3	55	-	Not used
RCPSettings.RegioBypassTime	I,3	56	120 min	Time in Bypass mode (min)
RCPSettings.RegioPresenceOffTime	I,3	57	10 min	Off delay for changing to no presence (min)
RCPSettings.RegioPresenceOnTime	I,3	58	0 min	On delay for changing to presence (min)
RCPSettings.RegioCVHeatPeriodTime	I,3	59	60 sec	Period time if pulse prop. control valves heating (sec)
RCPSettings.RegioCVCoolPeriodTime	I,3	60	60 sec	Period time if pulse prop. control valves cooling (sec)
RCPSettings.RegioCVHeatRunTime	I,3	61	120 sec	Run time close to open valve heating (sec)
RCPSettings.RegioCVCoolRunTime	I,3	62	120 sec	Run time close to open valve cooling (sec)
RCPInternal.RegioNotUsedX	X,3	63	-	Not used
RCPInternal.RegioNotUsedX	X,3	64	-	Not used
RCPInternal.RegioNotUsedX	X,3	65	-	Not used
RCPInternal.RegioNotUsedX	X,3	66	-	Not used
RCPInternal.RegioNotUsedX	X,3	67	-	Not used
RCPSettings.RegioOccSetPHeat	R,3	68	22 °C	Basic heating setpoint
RCPSettings.RegioOccSetPCool	R,3	69	24 °C	Basic cooling setpoint
RCPSettings.RegioStandbySetPDeadBand	R,3	70	3 °C	Deadband in Standby mode
RCPSettings.RegioUnOccSetPHeat	R,3	71	15 °C	Heating setpoint in Unoccupied mode
RCPSettings.RegioUnOccSetPCool	R,3	72	30 °C	Cooling setpoint in Unoccupied mode
RCPSettings.RegioFrostSetP	R,3	73	8 °C	Frost protection setpoint

RCPSettings.RegioSetpointOffsetPos	R,3	74	3 °C	Max setpoint adjustment pos
RCPSettings.RegioSetpointOffsetNeg	R,3	75	3 °C	Max setpoint adjustment neg
RCPSettings.RegioSetPOffset	R,3	76	0 °C	Setpoint adjustment
RCPSettings.RegioPIDPGain	R,3	77	10 °C	Room controller P-band
RCPSettings.RegioPIDTime	R,3	78	300 sec	Room controller I-time
RCPSettings.RegioCVDeadband	R,3	79	2 %	Deadband control valve
RCPSettings.RegioAIChangeOverLimitLow	R,3	80	18 °C	If lower change-over temperature, the controller is cooling
RCPSettings.RegioAIChangeOverLimitHigh	R,3	81	22 °C	If higher change-over temperature, the controller is heating
RCPSettings.RegioAi1Comp	R,3	82	0 °C	Analog input 1 compensation
RCPSettings.RegioAi2Comp	R,3	83	0 °C	Analog input 2 compensation
RCPSettings.RegioInternalTempComp	R,3	84	0 °C	Internal room sensor compensation
RCPSettings.RegioTempFilterFactor	R,3	85	0.2°C	Filter factor for temperature on analogue input 0 = No filter 1 = Max filter
RCPSettings.RegioMinFlow	R,3	86	20 %	Min flow of cool output when control state "Heat/Cool with VAV-control" is configured
RCPSettings.RegioMaxFlowHeat	R,3	87	80 %	Max flow of cool output when control state "Heat/Cool with VAV-control" is configured and heating is controlling the cool output
RCPInternal.RegioNotUsedX	X,3	88	-	Not used
RCPInternal.RegioNotUsedX	X,3	89	-	Not used
RCPInternal.RegioNotUsedX	X,3	90	-	Not used
RCPInternal.RegioNotUsedX	X,3	91	-	Not used
RCPInternal.RegioNotUsedX	X,3	92	-	Not used
RCPInternal.RegioNotUsedX	X,3	93	-	Not used
RCPSettings.RegioHeatOutputManual	R,3	94	0 %	Manual value heat output (0...100%)
RCPSettings.RegioCoolOutputManual	R,3	95	0 %	Manual value cool output (0...100%)
RCPSettings.RegioRoomTempRemote	R,3	96	5	Is used for remote control of the room temperature (-255 = no remote control of the room temperature.) External room sensor must be selected.
RCPInternal.RegioNotUsedX	X,3	97	-	Not used
RCPInternal.RegioNotUsedX	X,3	98	-	Not used
RCPInternal.RegioNotUsedX	X,3	99	-	Not used
RCPSettings.RegioCVHeatExerciseDay	X,3	100	8	Day for exercise of heating actuator: 0 = Never 1-7 = Mon-Sun 8 = Every day
RCPSettings.RegioCVCoolExerciseDay	X,3	101	8	Day for exercise of cooling actuator
RCPSettings.RegioCVHeatExerciseHour	X,3	102	15	Hour for exercise of heating actuator
RCPSettings.RegioCVCoolExerciseHour	X,3	103	15	Hour for exercise of cooling actuator
RCPSettings.RegioCVHeatExerciseMin	X,3	104	0	Minute for exercise of heating actuator
RCPSettings.RegioCVCoolExerciseMin	X,3	105	0	Minute for exercise of cooling actuator

RCPSettings.RegioALarmCategory(1)	X,3	106	3	Alarm category for presence: 0 = A alarm 1 = B alarm 2 = C alarm 3 = Event 4 = Disabled
RCPSettings.RegioALarmCategory(2)	X,3	107	3	Alarm category for open window
RCPSettings.RegioALarmCategory(3)	X,3	108	0	Alarm category for condensation
RCPSettings.RegioALarmCategory(4)	X,3	109	0	Alarm category for room temp high
RCPSettings.RegioALarmCategory(5)	X,3	110	0	Alarm category for room temp low
RCPSettings.RegioALarmCategory(6)	X,3	111	0	Alarm category for room temp deviation
RCPSettings.RegioALarmCategory(7)	X,3	112	2	Alarm category for room controller in manual mode
RCPSettings.RegioALarmCategory(8)	X,3	113	0	Alarm category for sensor alarm
RCPSettings.RegioLightFunction	X,3	114	0	Select lighting control function: 0 = Manual control 1 = Time control 2 = Presence control 3 = Time or presence control
RCPSettings.RegioLightSelect	X,3	115	2	Manual/Auto control of the lighting: 0 = Off 1 = Manual On 2 = Auto
RCPSettings.RegioJalusiRunTime	I,3	116	240 sec	Run time for controlling the blinds in/out (sec)
RCPSettings.RegioCond_0V	R,4	117	0 %	Condensation at 0 volt input
RCPSettings.RegioCond_10V	R,4	118	100 %	Condensation at 10 volt input
RCPSettings.RegioCO2_0V	R,4	119	0ppm	CO ₂ at 0 V input signal
RCPSettings.RegioCO2_10V	R,4	120	1000ppm	CO ₂ at 10 V input signal
RCPSettings.RegioRH_0V	R,4	121	0 RH	RH at 0 V input signal
RCPSettings.RegioRH_10V	R,4	122	100 RH	RH at 10 V input signal
RCPSettings.RegioCondFilterFactor	R,4	123	0.2	Filter factor for condensation on analog input: 0 = No filter 1 = Max filter
RCPSettings.RegioCO2FilterFactor	R,4	124	0.2	Filter factor for CO ₂ on analog input: 0 = No filter 1 = Max filter
RCPSettings.RegioRHFilterFactor	R,4	125	0.2	Filter factor for RH on analogue input: 0 = No filter 1 = Max filter
RCPSettings.RegioAlarmHyst	R,4	126	0.2°C	Alarm hysteresis
RCPSettings.RegioRoomTempHigh	R,4	127	40°C	High room temp
RCPSettings.RegioRoomTempLow	R,4	128	15°C	Low room temp
RCPSettings.RegioMaxDevRoom	R,4	129	20°C	Max allowed difference between setpoint and room temp before alarm
RCPSettings.RegioCondensationLimit	R,4	130	80%	High limit for condensation alarm
RCPSettings.RegioCondensationHyst	R,4	131	2%	Condensation alarm hysteresis
RCPSettings.RegioCO2PresenceLimit	R,4	132	800	Activate presence if CO ₂ is higher
RCPSettings.RegioCO2PresenceHyst	R,4	133	160	Diff for deactivate presence on CO ₂
RCPSettings.RegioDigOutSelect(0)	X,3	134	-	Not used

RCPSettings.RegioDigOut1Select	X,3	135	2	Manual/Auto digital output 1: 0 = Manual off 1 = Manual on 2 = Auto
RCPSettings.RegioDigOut2Select	X,3	136	2	Manual/Auto digital output 2
RCPSettings.RegioDigOut3Select	X,3	137	2	Manual/Auto digital output 3
RCPSettings.RegioDigOut4Select	X,3	138	2	Manual/Auto digital output 4
RCPSettings.RegioDigOut5Select	X,3	139	2	Manual/Auto digital output 5
RCPSettings.RegioDigOut6Select	X,3	140	2	Manual/Auto digital output 6
RCPSettings.RegioDigOut7Select	X,3	141	2	Manual/Auto digital output 7
RCPSettings.RegioAnaOut1Select	X,3	142	2	Manual/Auto analogue output 1
RCPSettings.RegioAnaOut2Select	X,3	143	2	Manual/Auto analogue output 2
RCPSettings.RegioAnaOut1Manual	R,3	144	0	Manual value AO1
RCPSettings.RegioAnaOut2Manual	R,3	145	0	Manual value AO2
RCPInternal.RegioNotUsedX	X,3	146	-	Not used
RCPInternal.RegioNotUsedX	X,3	147	-	Not used
RCPInternal.RegioNotUsedX	X,3	148	-	Not used
RCPInternal.RegioNotUsedX	X,3	149	-	Not used
TimeDp.Posts(0).T1	R,3	150	0	Start time per 1 Monday Occupied (HH.MM)
TimeDp.Posts(0).T2	R,3	151	0	Stop time per 1 Monday Occupied
TimeDp.Posts(0).T3	R,3	152	0	Start time per 2 Monday Occupied
TimeDp.Posts(0).T4	R,3	153	0	Stop time per 2 Monday Occupied
TimeDp.Posts(1).T1	R,3	154	0	Start time per 1 Tuesday Occupied
TimeDp.Posts(1).T2	R,3	155	0	Stop time per 1 Tuesday Occupied
TimeDp.Posts(1).T3	R,3	156	0	Start time per 2 Tuesday Occupied
TimeDp.Posts(1).T4	R,3	157	0	Stop time per 2 Tuesday Occupied
TimeDp.Posts(2).T1	R,3	158	0	Start time per 1 Wednesday Occupied
TimeDp.Posts(2).T2	R,3	159	0	Stop time per 1 Wednesday Occupied
TimeDp.Posts(2).T3	R,3	160	0	Start time per 2 Wednesday Occupied
TimeDp.Posts(2).T4	R,3	161	0	Stop time per 2 Wednesday Occupied
TimeDp.Posts(3).T1	R,3	162	0	Start time per 1 Thursday Occupied
TimeDp.Posts(3).T2	R,3	163	0	Stop time per 1 Thursday Occupied
TimeDp.Posts(3).T3	R,3	164	0	Start time per 2 Thursday Occupied
TimeDp.Posts(3).T4	R,3	165	0	Stop time per 2 Thursday Occupied
TimeDp.Posts(4).T1	R,3	166	0	Start time per 1 Friday Occupied
TimeDp.Posts(4).T2	R,3	167	0	Stop time per 1 Friday Occupied
TimeDp.Posts(4).T3	R,3	168	0	Start time per 2 Friday Occupied
TimeDp.Posts(4).T4	R,3	169	0	Stop time per 2 Friday Occupied
TimeDp.Posts(5).T1	R,3	170	0	Start time per 1 Saturday Occupied
TimeDp.Posts(5).T2	R,3	171	0	Stop time per 1 Saturday Occupied
TimeDp.Posts(5).T3	R,3	172	0	Start time per 2 Saturday Occupied
TimeDp.Posts(5).T4	R,3	173	0	Stop time per 2 Saturday Occupied
TimeDp.Posts(6).T1	R,3	174	0	Start time per 1 Sunday Occupied
TimeDp.Posts(6).T2	R,3	175	0	Stop time per 1 Sunday Occupied
TimeDp.Posts(6).T3	R,3	176	0	Start time per 2 Sunday Occupied
TimeDp.Posts(6).T4	R,3	177	0	Stop time per 2 Sunday Occupied

TimeDp.Posts(7).T1	R,3	178	0	Start time per 1 holiday Occupied
TimeDp.Posts(7).T2	R,3	179	0	Stop time per 1 holiday Occupied
TimeDp.Posts(7).T3	R,3	180	0	Start time per 2 holiday Occupied
TimeDp.Posts(7).T4	R,3	181	0	Stop time per 2 holiday Occupied
TimeDp.Posts(8).T1	R,3	182	0	Start time per 1 Monday Unoccupied (HH.MM)
TimeDp.Posts(8).T2	R,3	183	0	Stop time per 1 Monday Unoccupied
TimeDp.Posts(8).T3	R,3	184	0	Start time per 2 Monday Unoccupied
TimeDp.Posts(8).T4	R,3	185	0	Stop time per 2 Monday Unoccupied
TimeDp.Posts(9).T1	R,3	186	0	Start time per 1 Tuesday Unoccupied
TimeDp.Posts(9).T2	R,3	187	0	Stop time per 1 Tuesday Unoccupied
TimeDp.Posts(9).T3	R,3	188	0	Start time per 2 Tuesday Unoccupied
TimeDp.Posts(9).T4	R,3	189	0	Stop time per 2 Tuesday Unoccupied
TimeDp.Posts(10).T1	R,3	190	0	Start time per 1 Wednesday Unoccupied
TimeDp.Posts(10).T2	R,3	191	0	Stop time per 1 Wednesday Unoccupied
TimeDp.Posts(10).T3	R,3	192	0	Start time per 2 Wednesday Unoccupied
TimeDp.Posts(10).T4	R,3	193	0	Stop time per 2 Wednesday Unoccupied
TimeDp.Posts(11).T1	R,3	194	0	Start time per 1 Thursday Unoccupied
TimeDp.Posts(11).T2	R,3	195	0	Stop time per 1 Thursday Unoccupied
TimeDp.Posts(11).T3	R,3	196	0	Start time per 2 Thursday Unoccupied
TimeDp.Posts(11).T4	R,3	197	0	Stop time per 2 Thursday Unoccupied
TimeDp.Posts(12).T1	R,3	198	0	Start time per 1 Friday Unoccupied
TimeDp.Posts(12).T2	R,3	199	0	Stop time per 1 Friday Unoccupied
TimeDp.Posts(12).T3	R,3	200	0	Start time per 2 Friday Unoccupied
TimeDp.Posts(12).T4	R,3	201	0	Stop time per 2 Friday Unoccupied
TimeDp.Posts(13).T1	R,3	202	0	Start time per 1 Saturday Unoccupied
TimeDp.Posts(13).T2	R,3	203	0	Stop time per 1 Saturday Unoccupied
TimeDp.Posts(13).T3	R,3	204	0	Start time per 2 Saturday Unoccupied
TimeDp.Posts(13).T4	R,3	205	0	Stop time per 2 Saturday Unoccupied
TimeDp.Posts(14).T1	R,3	206	0	Start time per 1 Sunday Unoccupied
TimeDp.Posts(14).T2	R,3	207	0	Stop time per 1 Sunday Unoccupied
TimeDp.Posts(14).T3	R,3	208	0	Start time per 2 Sunday Unoccupied
TimeDp.Posts(14).T4	R,3	209	0	Stop time per 2 Sunday Unoccupied
TimeDp.Posts(15).T1	R,3	210	0	Start time per 1 holiday Unoccupied
TimeDp.Posts(15).T2	R,3	211	0	Stop time per 1 holiday Unoccupied
TimeDp.Posts(15).T3	R,3	212	0	Start time per 2 holiday Unoccupied
TimeDp.Posts(15).T4	R,3	213	0	Stop time per 2 holiday Unoccupied
TimeDp.Posts(16).T1	R,3	214	0	Start time per 1 Monday Lighting (HH.MM)
TimeDp.Posts(16).T2	R,3	215	0	Stop time per 1 Monday Lighting
TimeDp.Posts(16).T3	R,3	216	0	Start time per 2 Monday Lighting
TimeDp.Posts(16).T4	R,3	217	0	Stop time per 2 Monday Lighting
TimeDp.Posts(17).T1	R,3	218	0	Start time per 1 Tuesday Lighting
TimeDp.Posts(17).T2	R,3	219	0	Stop time per 1 Tuesday Lighting
TimeDp.Posts(17).T3	R,3	220	0	Start time per 2 Tuesday Lighting
TimeDp.Posts(17).T4	R,3	221	0	Stop time per 2 Tuesday Lighting

TimeDp.Posts(18).T1	R,3	222	0	Start time per 1 Wednesday Lighting
TimeDp.Posts(18).T2	R,3	223	0	Stop time per 1 Wednesday Lighting
TimeDp.Posts(18).T3	R,3	224	0	Start time per 2 Wednesday Lighting
TimeDp.Posts(18).T4	R,3	225	0	Stop time per 2 Wednesday Lighting
TimeDp.Posts(19).T1	R,3	226	0	Start time per 1 Thursday Lighting
TimeDp.Posts(19).T2	R,3	227	0	Stop time per 1 Thursday Lighting
TimeDp.Posts(19).T3	R,3	228	0	Start time per 2 Thursday Lighting
TimeDp.Posts(19).T4	R,3	229	0	Stop time per 2 Thursday Lighting
TimeDp.Posts(20).T1	R,3	230	0	Start time per 1 Friday Lighting
TimeDp.Posts(20).T2	R,3	231	0	Stop time per 1 Friday Lighting
TimeDp.Posts(20).T3	R,3	232	0	Start time per 2 Friday Lighting
TimeDp.Posts(20).T4	R,3	233	0	Stop time per 2 Friday Lighting
TimeDp.Posts(21).T1	R,3	234	0	Start time per 1 Saturday Lighting
TimeDp.Posts(21).T2	R,3	235	0	Stop time per 1 Saturday Lighting
TimeDp.Posts(21).T3	R,3	236	0	Start time per 2 Saturday Lighting
TimeDp.Posts(21).T4	R,3	237	0	Stop time per 2 Saturday Lighting
TimeDp.Posts(22).T1	R,3	238	0	Start time per 1 Sunday Lighting
TimeDp.Posts(22).T2	R,3	239	0	Stop time per 1 Sunday Lighting
TimeDp.Posts(22).T3	R,3	240	0	Start time per 2 Sunday Lighting
TimeDp.Posts(22).T4	R,3	241	0	Stop time per 2 Sunday Lighting
TimeDp.Posts(23).T1	R,3	242	0	Start time per 1 holiday Lighting
TimeDp.Posts(23).T2	R,3	243	0	Stop time per 1 holiday Lighting
TimeDp.Posts(23).T3	R,3	244	0	Start time per 2 holiday Lighting
TimeDp.Posts(23).T4	R,3	245	0	Stop time per 2 holiday Lighting
TimeHp.Posts(0).FromDate	R,3	246	01.01	Start date holiday period 1 (MM.DD)
TimeHp.Posts(0).ToDate	R,3	247	01.01	Stop date holiday period 1 (MM.DD)
TimeHp.Posts(1).FromDate	R,3	248	01.01	Start date holiday period 2 (MM.DD)
TimeHp.Posts(1).ToDate	R,3	249	01.01	Stop date holiday period 2 (MM.DD)
TimeHp.Posts(2).FromDate	R,3	250	01.01	Start date holiday period 3 (MM.DD)
TimeHp.Posts(2).ToDate	R,3	251	01.01	Stop date holiday period 3 (MM.DD)
TimeHp.Posts(3).FromDate	R,3	252	01.01	Start date holiday period 4 (MM.DD)
TimeHp.Posts(3).ToDate	R,3	253	01.01	Stop date holiday period 4 (MM.DD)
TimeHp.Posts(4).FromDate	R,3	254	01.01	Start date holiday period 5 (MM.DD)
TimeHp.Posts(4).ToDate	R,3	255	01.01	Stop date holiday period 5 (MM.DD)
TimeHp.Posts(5).FromDate	R,3	256	01.01	Start date holiday period 6 (MM.DD)
TimeHp.Posts(5).ToDate	R,3	257	01.01	Stop date holiday period 6 (MM.DD)
TimeHp.Posts(6).FromDate	R,3	258	01.01	Start date holiday period 7 (MM.DD)
TimeHp.Posts(6).ToDate	R,3	259	01.01	Stop date holiday period 7 (MM.DD)
TimeHp.Posts(7).FromDate	R,3	260	01.01	Start date holiday period 8 (MM.DD)
TimeHp.Posts(7).ToDate	R,3	261	01.01	Stop date holiday period 8 (MM.DD)
TimeHp.Posts(8).FromDate	R,3	262	01.01	Start date holiday period 9 (MM.DD)
TimeHp.Posts(8).ToDate	R,3	263	01.01	Stop date holiday period 9 (MM.DD)
TimeHp.Posts(9).FromDate	R,3	264	01.01	Start date holiday period 10 (MM.DD)
TimeHp.Posts(9).ToDate	R,3	265	01.01	Stop date holiday period 10 (MM.DD)

Alarms.AlaAcknow	X,3	266	255	External alarms are acknowledged by setting this signal to the alarm number that you want to acknowledge
Alarms.AlaBlock	X,3	267	255	External alarms are blocked by setting this signal to the alarm number that you want to block
Alarms.AlaUnBlock	X,3	268	255	External alarms are unblocked by setting this signal to the alarm number that you want to unblock
QSystem.Sek	X,3	269	-	Real-time clock: Second 0-59
QSystem.Minute	X,3	270	-	Real-time clock: Minute 0-59
QSystem.Hour	X,3	271	-	Real-time clock: Hour 0-23
QSystem.WDay	X,3	272	-	Real-time clock: Weekday 1-7, 1=Monday
QSystem.Week	X,3	273	-	Real-time clock: Week number 1-53
QSystem.Date	X,3	274	-	Real-time clock: Day of the month 1-31
QSystem.Month	X,3	275	-	Real-time clock: Month 1-12
QSystem.Year	X,3	276	-	Real-time clock: Year 0-99

LonWorks network variables

Name	Type	Description
Configuration		
nciSndHrtBt	SNVT_time_sec	Pulse (0=disabled)
nciRcvHrtBt	SNVT_time_sec	Max. time before a requested value is discarded
nciSetPnts	SNVT_temp_setpt	Setpoints
nciHvacType	SNVT_hvac_type	Model
nciBypassTime	SNVT_time_min	Time in bypass mode
nciCO2PresenceHyst	SNVT_ppm	Hysteresis for inactivation of occupancy
nciCO2PresLimit	SNVT_ppm	CO ₂ concentration at which occupancy is activated
nciCO2LimitLow	SNVT_ppm	CO ₂ concentration at which the dampers start to open
nciCO2LimitHigh	SNVT_ppm	CO ₂ concentration at which the dampers are completely open
nciPpmHyst	SNVT_ppm	Hysteresis before ppm values are transmitted via the bus
nciTempHyst	SNVT_temp_p	Hysteresis before temperature values are transmitted via the bus
nciPercentHyst	SNVT_lev_percent	Hysteresis before percentages are transmitted via the bus
Inputs (nvi)		
nviSpaceTemp	SNVT_temp_p	Room temperature
nviSetPtOffset	SNVT_temp_p	Setpoint offset
nviOccManCmd	SNVT_occupancy	Setting of running mode, Occ/UnOcc/By/Standby

nviOccSensor	SNVT_occupancy	Signal from an occupancy detector On/Off
nviHeatCool	SNVT_hvac_mode	Change-over
nviEnergyHoldOff	SNVT_switch	Open window
nviSourceTemp	SNVT_temp_p	AI change-over
nviOutdoorTemp	SNVT_temp_p	Outdoor temperature
nviSpaceRH	SNVT_lev_percent	Relative humidity in the room
nviSpaceIAQ	SNVT_ppm	CO ₂ concentration in the room
nviCondenseSens	SNVT_percent	Condensation detector
nviCondenseGuard	SNVT_switch	Condensation detector On/Off
Outputs (nvo)		
nvoSpaceTemp	SNVT_temp_p	Room temperature
nvoUnitStatus	SNVT_hvac_status	Running mode, controller
nvoEffectSetPt	SNVT_temp_p	PID setpoint
nvoEffectOccup	SNVT_occupancy	Running mode, Regio unit
nvoHeatCool	SNVT_hvac_mode	Running mode, heating/cooling
nvoFanSpeed	SNVT_switch	Current fan speed
nvoTerminalLoad	SNVT_lev_percent	Total output signal
nvoHeatPrimary	SNVT_lev_percent	Output heating
nvoCoolPrimary	SNVT_lev_percent	Output cooling
nvoSpaceRH	SNVT_lev_percent	Relative humidity in the room
nvoOutdoorTemp	SNVT_temp_p	Outdoor temperature
nvoSpaceCO2	SNVT_ppm	CO ₂ concentration in the room
nvoEnergyHoldOff	SNVT_switch	Open window
nvoCondenseSens	SNVT_lev_percent	Condensation detector
nvoLightControl	SNVT_switch	Lighting On/Off
nvoLJalousieIn	SNVT_switch	Blind in
nvoJalousieOut	SNVT_switch	Blind out
nvoAlarm	SNVT_state	Alarm

***Part VI* Index**

+

+C 14

A

About the manual 6
 More information 6
 Terms 6
Accessories for Regio Maxi 15
Activation of the different operating modes 53
Actuators 59
 Analogue actuators 59
 Exercise 59
 Thermal actuators 59
 Three-point actuators 59
AI 14
Analogue actuators 59
Analogue inputs 14
Analogue outputs 14
AO 14
Application examples 9
Applications 7
Auto control 60

B

Basic models 11
Basic setpoint 57
Battery 14
Battery backup 14
Bypass 53

C

Calculation of the active setpoint 57
Central command 55
Central control 55
Change-over function 61
Changing the battery 76
CI 14
CO₂-sensor 66
Communication 8
Communication port
 Port 1 14
 TCP/IP port 14
Communication ports 14
Condensation detector 62
Condensation input 14
Configuration 18
Control of blinds 65
Control states 49
 Cooling 51
 Cooling/Cooling 51

Heating 49
Heating or cooling via the change-over function 49
Heating/Cooling 50
Heating/Cooling with VAV-control 50
Heating/Cooling with VAV-control and forced
 supply air function 50
Heating/Heating 49
Cooling 51
Cooling/Cooling 51

D

DI 14
Digital inputs 14
Digital outputs 14
Dipswitches 19
Display handling 67
 Indications 67
DO 14

E

Exercise 59

F

Fan control 60
 Auto control 60
 Manual control 60
 Off/Unoccupied 60
 Select button 60
Forced ventilation 62
Frost protection 62

G

GDO 14

H

Heating 49
Heating or cooling via the change-over function 49
Heating/Cooling 50
Heating/Cooling with VAV-control and forced supply
 air function 50
Heating/Heating 49
Humidity sensor 66

I

INCREASE/DECREASE button 67
Indications 63, 67

Communication	63	Parameters	68
Occupancy button	63	Port 1	14
Inputs		Preset operating mode	53
Analogue	14		
Condensation	14		
Digital	14		
Installation	20		
preparations	18		
Introduction to Regio Maxi	7		
L		R	
Labels	18	Relay outputs	14
Lighting control	65	Remove the cover	77
Local time control	54	Resetting the application memory	77
LON communication	8	RU-DOS	11
		RU-F-models	11
M		S	
Maintenance and service	76	Select button	60, 68
Manual control	60	Setpoint calculation	57
Models	10	Calculation of the active setpoint	57
More information	6	Setpoint displacement	57
Mounting	7, 20	Shutdown	54
		Special input CI	62
		Split output signal	49, 51
		Stand-by	52, 58
		SW1-4	19
		T	
O		TCP/IP port	14
Occupancy button	53, 55, 63	Technical data	13
Occupancy detector	54, 55	Terms	6
Occupied	53	Thermal actuators	59
Occupied/Bypass	58	Three-point actuators	59
Off	52, 57		
Off/Unoccupied	60		
Operating modes	52		
Operating modes			
Occupied	53		
Outdoor temperature sensor	66		
Outputs			
24 V DC	14		
Analogue	14		
Digital MosFet	14		
Digital relays	14		
GDO (24 V AC)	14		
P		U	
Parameter menu	68	Unoccupied	52, 57
		V,W	
		Wiring	22
		Wiring for RCP100 / RCP100T / RCP100L	24
		Wiring for RCP100F / RCP100FT / RCP100FL	30
		Wiring for RCP200 / RCP200T / RCP200L	36
		Wiring for RCP200F / RCP200FT / RCP200FL	41
		Wiring for RU-...	23

REGIN - THE CHALLENGER IN BUILDING AUTOMATION

AB Regin

Head office

Box 116, S-428 22 Källered,
Sweden

Phone: +46 31 720 02 00

Fax: +46 31 720 02 50

info@regin.se

www.regincontrols.com



THE CHALLENGER IN BUILDING AUTOMATION